

Mini-ITX Addendum Version 2.0

To the microATX Motherboard Interface Specification Version 1.2

October 2010

1. INTEL CORPORATION (“INTEL”) MAKES NO WARRANTIES WITH REGARD TO THIS SPECIFICATION (“SPECIFICATION”), AND IN PARTICULAR DOES NOT WARRANT OR REPRESENT THAT THIS SPECIFICATION OR ANY PRODUCTS MADE IN CONFORMANCE WITH IT WILL WORK IN THE INTENDED MANNER. NOR DOES INTEL ASSUME RESPONSIBILITY FOR ANY ERRORS THAT THE SPECIFICATION MAY CONTAIN OR HAVE ANY LIABILITIES OR OBLIGATIONS FOR DAMAGES INCLUDING, BUT NOT LIMITED TO, SPECIAL, INCIDENTAL, INDIRECT, PUNITIVE, OR CONSEQUENTIAL DAMAGES WHETHER ARISING FROM OR IN CONNECTION WITH THE USE OF THIS SPECIFICATION IN ANY WAY.

2. NO REPRESENTATIONS OR WARRANTIES ARE MADE THAT ANY PRODUCT BASED IN WHOLE OR IN PART ON THE ABOVE SPECIFICATION WILL BE FREE FROM DEFECTS OR SAFE FOR USE FOR ITS INTENDED PURPOSE. ANY PERSON MAKING, USING OR SELLING SUCH PRODUCT DOES SO AT HIS OR HER OWN RISK.

3. THE USER OF THIS SPECIFICATION HEREBY EXPRESSLY ACKNOWLEDGES THAT THE SPECIFICATION IS PROVIDED AS IS, AND THAT INTEL MAKES NO REPRESENTATIONS, EXTENDS NO WARRANTIES OF ANY KIND, EITHER EXPRESS OR IMPLIED, ORAL OR WRITTEN, INCLUDING ANY WARRANTY OF MERCHANTABILITY OR FITNESS FOR A PARTICULAR PURPOSE, OR WARRANTY OR REPRESENTATION THAT THE SPECIFICATION OR ANY PRODUCT OR TECHNOLOGY UTILIZING THE SPECIFICATION OR ANY SUBSET OF THE SPECIFICATION WILL BE FREE FROM ANY CLAIMS OF INFRINGEMENT OF ANY INTELLECTUAL PROPERTY, INCLUDING PATENTS, COPYRIGHT AND TRADE SECRETS NOR DOES INTEL ASSUME ANY OTHER RESPONSIBILITIES WHATSOEVER WITH RESPECT TO THE SPECIFICATION OR SUCH PRODUCTS.

4. YOU MAY COPY AND REPRODUCE THIS SPECIFICATION FOR ANY PURPOSE PROVIDED THIS “IMPORTANT INFORMATION AND DISCLAIMERS” SECTION (PARAGRAPHS 1-4) IS PROVIDED IN WHOLE ON ANY COPIES YOU MAKE. NO OTHER LICENSE, EXPRESS OR IMPLIED, BY ESTOPPEL OR OTHERWISE, TO ANY OTHER INTELLECTUAL PROPERTY RIGHTS IS GRANTED HEREIN.

Intel is a trademark of Intel Corporation in the U.S. and other countries.

* Other names and brands may be claimed as the property of others. Copyright © 2010 Intel Corporation

Contents

Revision History.....	4
1	Executive Summary 5
1.1	Terminology 6
1.2	Reference Documents..... 6
1.3	Benefits to Users 6
1.4	Benefits to Manufacturers 6
2	Layout..... 8
2.1	Board Dimensions 9
2.2	Mounting Hole Placement..... 9
2.3	Connector Placement..... 11
2.3.1	Thin Mini-ITX Back Panel I/O..... 11
2.4	Height Constraints 11
2.4.1	Mini-ITX: Primary (Component) Side Height Constraints 11
2.4.2	Thin Mini-ITX: Primary (Component) Side Height Constraints..... 12
2.4.3	Secondary (Bottom/Solder) Side Height Constraints 14
2.4.4	Thin Mini-ITX System Considerations 14
3	Power Supply Information..... 16

Figures

Figure 1. Example Mini-ITX Layout for SFF Desktop	8
Figure 2. ATX, microATX, and Mini-ITX Mounting Holes.....	9
Figure 3. Mini-ITX Board Diagram	10
Figure 4. Thin Mini-ITX Back Panel I/O	11
Figure 5. Mini-ITX Maximum Component Height Restrictions	12
Figure 6. Thin Mini-ITX Maximum Component Height Restrictions	14

Tables

Table 1. Mini-ITX Addendum Feature Summary	5
Table 2. Compares ATX, microATX, and Mini-ITX Board Dimensions.....	9
Table 3. Motherboard Mounting Hole Locations	10

Revision History

Revision Number	Description	Revision Date
2.0	Added Thin Mini-ITX definition.	Oct, 2010
1.1	Minor corrections made. Title changed to: 'Mini-ITX Addendum Version 1.1 To the microATX Motherboard Interface Specification Version 1.2' to reflect full name of mATX document name.	Feb, 2009
1.0	Initial release.	Feb, 2009

§

1 Executive Summary

The Mini-ITX addendum to the *microATX Motherboard Interface Specification* details the use of the Mini-ITX form factor standard, developed by Via Technologies Inc, for compatibility with Intel based platforms. This document defines only the specific features in Intel's Mini-ITX based platforms that differ from those of microATX and should be used in conjunction with the governing microATX specification.

A smaller motherboard layout offers system developers the ability to create new and innovative system designs. This smaller version of microATX allows and encourages developers to build within the sub 8 liter chassis volume for a variety of new applications.

Described within this document are requirements and characteristics of a Mini-ITX motherboard, so that a motherboard may function and fit appropriately when paired with a **Mini-ITX** chassis. Beyond this, it does not detail processor, memory, graphics or other system features required to meet the Mini-ITX form factor. These items are left to system designers and integrators within the guidelines of the microATX specification.

A further refinement of Mini-ITX boards is the **Thin Mini-ITX** board definition. Its smaller size enables system integrators to integrate sub-4 liter systems, such as Tiny PCs and All-In-One PCs, using a standard building block approach.

Table 1. Mini-ITX Addendum Feature Summary

Feature	Benefit
170mm x 170mm motherboard size	Smaller board size enables a smaller system size.
Mini-ITX: Standard microATX 1.2 or later I/O panel	ATX I/O shield does not need to be retooled. Motherboard can be used in an ATX, microATX, or Mini-ITX chassis.
Thin Mini-ITX: A Mini-ITX board targeted for smaller system form factors with a 20mm tall PCB and component volumetric, and a 1" back panel I/O height	A Thin Mini-ITX board can use a thin back panel I/O shield when targeted for Tiny PCs and AIOs. The same board can be used in a Mini-ITX, microATX, and ATX chassis when used with a regular ATX I/O shield.
Same motherboard mounting holes as in microATX	Compatible with microATX chassis. No need to retool current chassis.
Current processor and future processor technologies	Chassis will work for multi generation socketed processor technology.

This addendum does NOT define:

- Specific power supply form factors
- Thermal design guidance to chassis vendors (covered in TASC guide listed in Reference Documents)

The *Mini-ITX Addendum To the microATX Motherboard Interface Specification* is a public document intended for widespread application in many types of systems. It is available through a public website located at:

<http://www.formfactors.org>

1.1 Terminology

Term	Description
Small Form Factor (SFF)	8-19 liter chassis (IDC* definition)
Ultra SFF (uSFF)	4-8 liter chassis (IDC* definition)
Tiny PC	Less than 4 liter chassis (IDC* definition)
All-In-One (AIO) PC	An All-In-One is a desktop PC with a display built into the main computing unit (IDC* definition)

1.2 Reference Documents

The following reference documents are posted on the public web site at:

<http://www.formfactors.org>

Document
microATX Motherboard Interface Specification Version 1.2
SFX 12V Power Supply Design Guide
TFX 12V Power Supply Design Guide
Thermally Advantaged Small Chassis or TASC [pronounced 'task'] (Thermal Design Guide)

1.3 Benefits to Users

Trends in the industry indicate that users require a smaller and lower cost solution for their PC needs. Mini-ITX's smaller board size and lower height keep-out zones enable a reduced sized chassis as it sits on the user's desk, is mounted on a display, or comes in any other innovative form factor. These changes also enable a PC to be designed into various aesthetic shapes and sizes. The Thin Mini-ITX board variation leverages Mini-ITX's advantages, while enabling even thinner systems.

1.4 Benefits to Manufacturers

By manufacturing to the standard or thin variations of the Mini-ITX specification, motherboard manufacturers and chassis manufacturers can guarantee a better

compatibility between their products. They can also capitalize on the benefits of a reduction in total system costs because of a reduced system size. This specification allows chassis vendors to design their product targeting the soldered down, low power processors all the way up to high performance, multi-core processors. It eliminates the need for them to design targeted chassis for each platform.

§

2 *Layout*

This section describes the mechanical specifications of the Mini-ITX and Thin Mini-ITX form-factor motherboards. Size, mounting hole placement, connector placement, and component height constraints are specified. System components such as hard drives, disk drives, and power supplies are not specified; however, it is generally recommended to consider what would facilitate assembly, as well as not place components such that they block fan inlets. An example layout is depicted in Figure 1.

Thin Mini-ITX is a variant of standard Mini-ITX and shares most of the same requirements. Requirements are only different where new specifications are specifically defined for Thin Mini-ITX.

Figure 1. Example Mini-ITX Layout for SFF Desktop

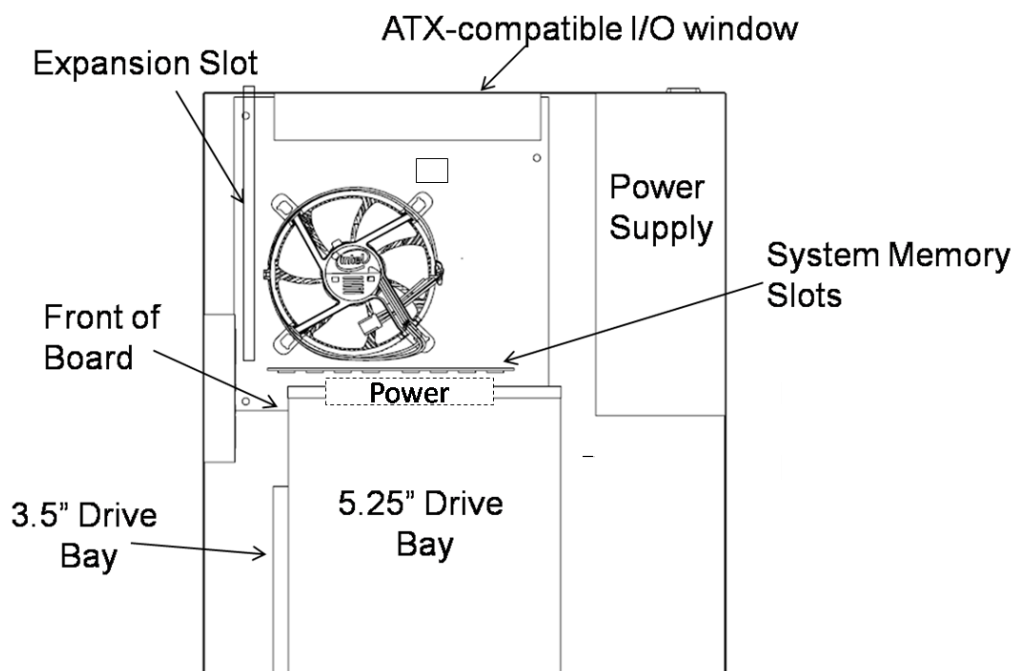

NOTE: Depicted system is approximately 8L with standard desktop components.

2.1 Board Dimensions

Table 2. Compares ATX, microATX, and Mini-ITX Board Dimensions

Dimension	ATX	microATX	Mini-ITX
Maximum width Allowable	305mm	244mm	170mm
Maximum depth Allowable	244mm	244mm	170mm

2.2 Mounting Hole Placement

Mini-ITX utilizes a subset of ATX mounting holes. To avoid damage to traces on motherboards, chassis standoffs in any locations not specified should be removable or not implemented at all. See Figure 2 for relative hole locations compared to ATX and microATX motherboards.

Figure 2. ATX, microATX, and Mini-ITX Mounting Holes

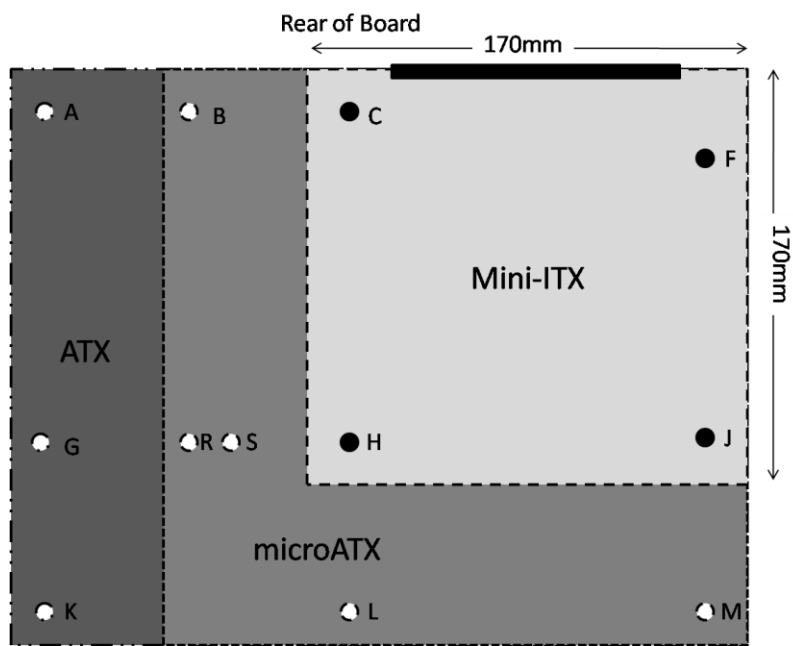

Not to scale

- NOTE:** Board is shown oriented with the rear of the board towards the top.
- NOTE:** The lighter portion indicates the approximate region of the Mini-ITX form factor.

Table 3. Motherboard Mounting Hole Locations

Form Factor	Mounting Hole Locations
Mini-ITX	C,F,H,J
microATX	B,C,F,H,J,L,M,R,S
ATX	A,C,F,G,H,J,K,L,M

Figure 3. Mini-ITX Board Diagram

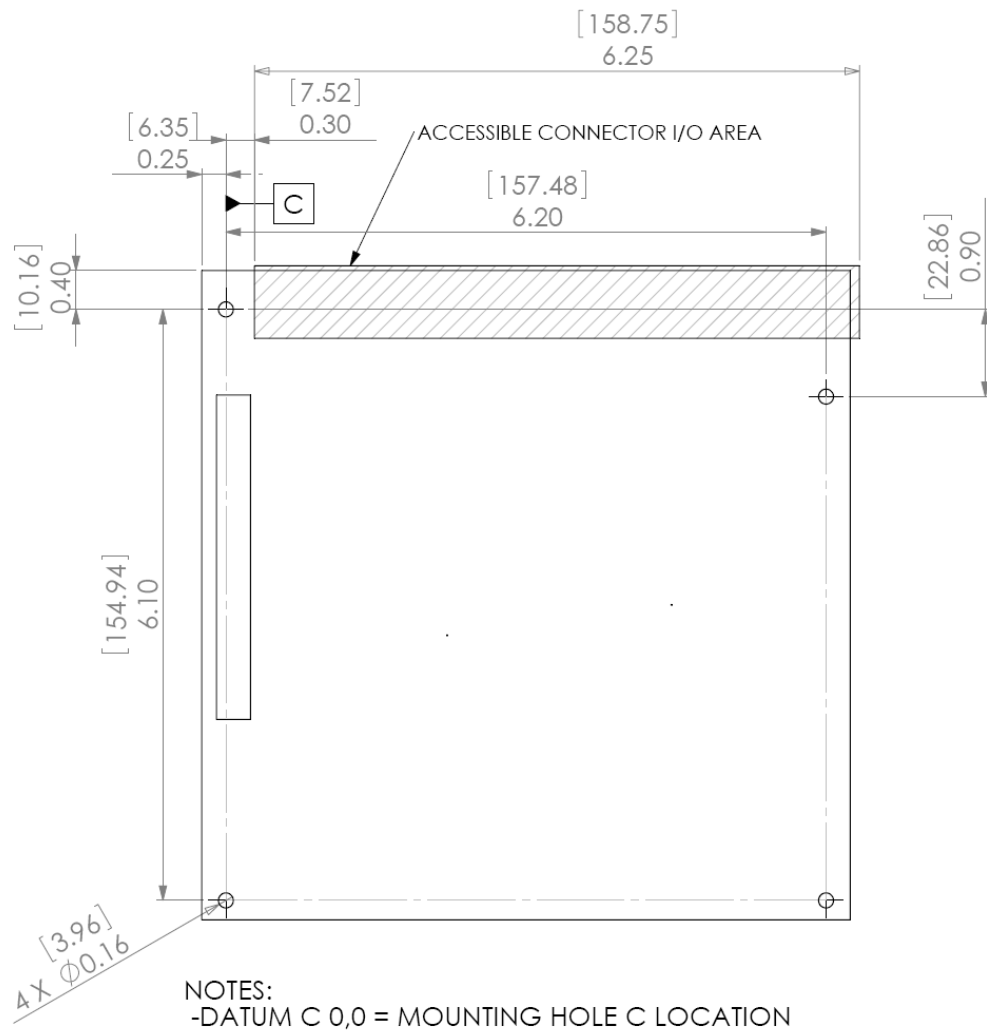

2.3 Connector Placement

For Mini-ITX, all connector locations as well as allowable placement area for I/O connectors on the back panel are described and can be found in the *microATX Interface Specification*.

2.3.1 Thin Mini-ITX Back Panel I/O

The Thin Mini-ITX Back Panel I/O area is defined in Figure 4. The width of the back panel I/O aperture and the location of the motherboard relative to the I/O aperture are the same as Mini-ITX. This allows a Thin Mini-ITX board to be used in either a Thin Mini-ITX chassis, or a Mini-ITX and larger compatible chassis when using an appropriate I/O shield.

The thickness of the PCB and the topside I/O connectors shall fit within the .787" (20mm) height shown in Figure 4. See section 2.4.2 for additional discussion.

Figure 4. Thin Mini-ITX Back Panel I/O

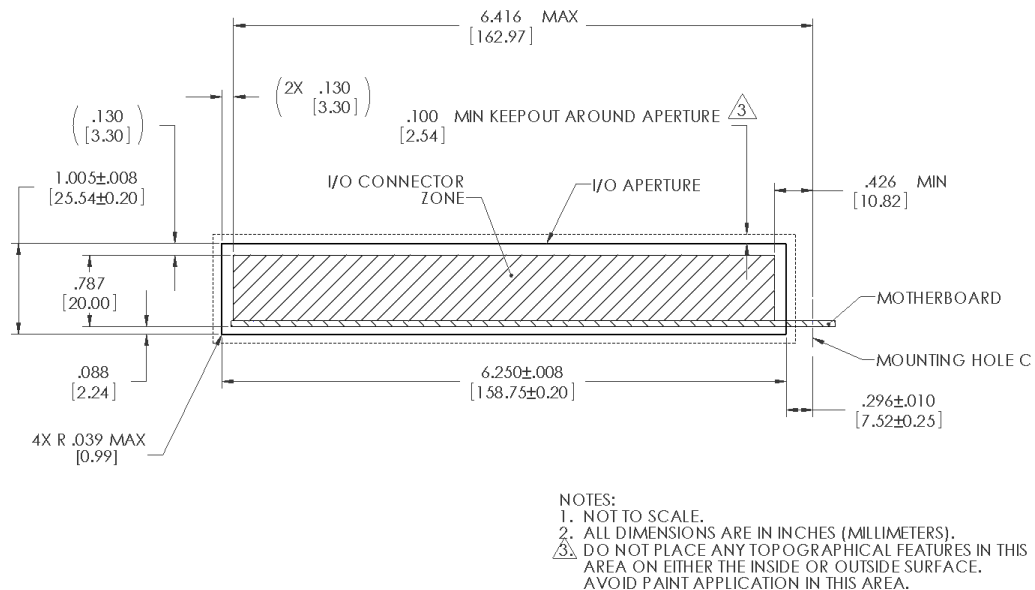

2.4 Height Constraints

2.4.1 Mini-ITX: Primary (Component) Side Height Constraints

One major advantage of the Mini-ITX form factor is its backward-compatibility with the ATX specification. The Mini-ITX motherboard can be installed in any ATX chassis. Figure 5 shows the required Mini-ITX **maximum component height constraints** for the components on the PC board. For full compliance with Mini-ITX, and to prevent interference with the chassis structure, power supply, or peripherals, the motherboard components should not exceed the height limit in each zone defined. Similarly, compliant power supplies, peripherals, and chassis features should not extend into the motherboard component area.

Figure 5. Mini-ITX Maximum Component Height Restrictions

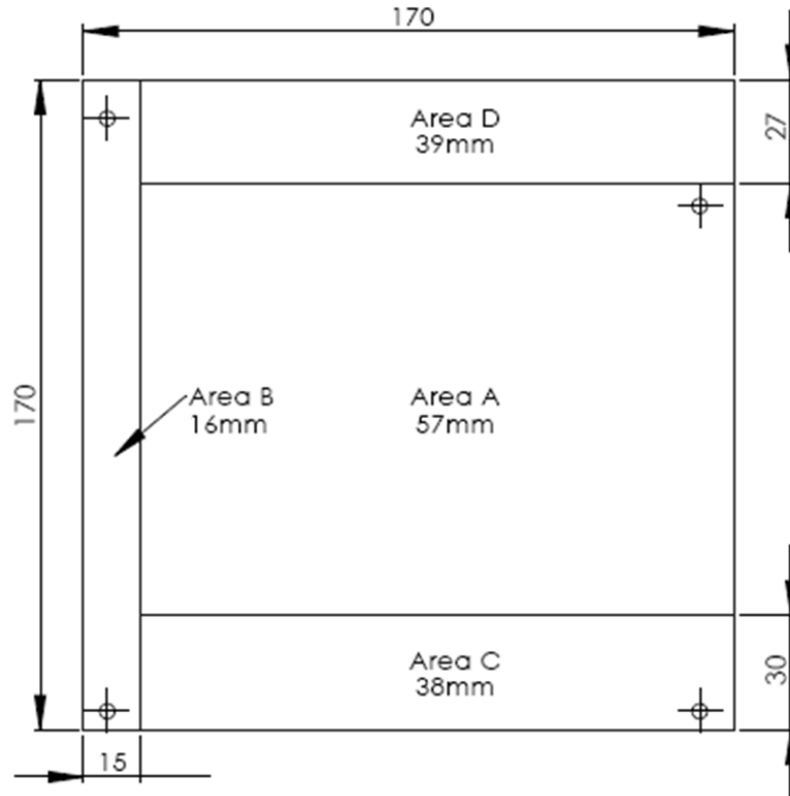

Notes:

- All dimensions in the above figure are in millimeters (mm).
- The 57mm height restriction in Area A applies to the PC board component height. The actual height of the chassis should include any dynamic excursion considerations for shipping as well as needs to facilitate alternative cooling solutions or airflow considerations.
- For the Intel boxed processor fan heat sink, it is strongly recommended not to place components between fan inlet and chassis side vent by leaving space between chassis wall and area A open.
- The component height requirement assumes a motherboard thickness of 1.57 mm (.062”).

2.4.2 Thin Mini-ITX: Primary (Component) Side Height Constraints

Figure 6 shows the required Thin Mini-ITX volumetric envelope for the PCB and all motherboard components. For full compliance with Thin Mini-ITX, and to prevent

interference with the chassis structure and other system components, the motherboard components must not exceed the height limit in each zone defined.

In Area A, the thickness of the PCB and the topside components shall fit within the .787" (20mm) height shown in Figure 6. With this in mind, motherboard designers may exercise tradeoffs between board thickness and the height of I/O components as necessary. For example, a .062" (1.57mm) PCB would allow .725" (18.43mm) for topside components, while a .093" (2.36mm) PCB would allow .694" (17.64mm).

Chassis features and system components must not extend into the motherboard component area. Additionally, space must be permitted around the motherboard by the chassis and other system components to allow for dynamic excursion considerations, as well as needs to facilitate alternative cooling solutions or airflow considerations.

Depending on the needs of the system, components that interface with the motherboard but are not part of it, such as a CPU heatsink, may fit within the volumetric established in Figure 6 or extend outside of it. Any components that extend through the motherboard volumetric must be selected in cooperation with the chassis to ensure there are no interference issues. The motherboard may have its own specific keep-in or keep-out requirements, such as around a CPU for its heatsink, which may also need to be considered.

Figure 6. Thin Mini-ITX Maximum Component Height Restrictions

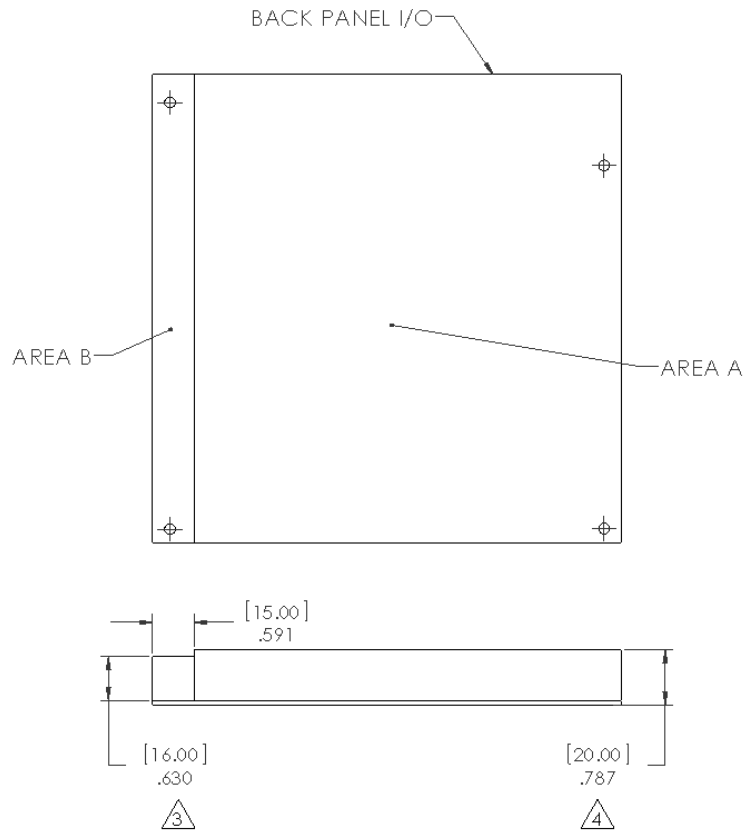

- NOTES:
 1. NOT TO SCALE.
 2. ALL DIMENSIONS ARE IN INCHES (MILLIMETERS).
 3. DIMENSIONED TO TOP OF PCB.
 4. DIMENSIONED TO BOTTOM OF PCB.

2.4.3 Secondary (Bottom/Solder) Side Height Constraints

No height restraints on secondary side are added or removed from what is specified in the microATX Motherboard Interface Specification.

2.4.4 Thin Mini-ITX System Considerations

While the low profile design of a Thin Mini-ITX motherboard creates the opportunity for smaller PCs, system space must be allowed for factors such as airflow and cabling. Board headers and the cable connectors they mate to should be selected with size and orientation in mind. The use of tall headers which are perpendicular to the motherboard and/or long cable connectors increase the chance of interference with chassis components immediately over a Thin Mini-ITX board.

System integration challenges can be addressed in a variety of ways, including:

- Carefully considering venting and fan/blower strategies to ensure proper cooling can be achieved in a small chassis.
- Minimizing the size of board headers and cable connectors.
- Using board headers which are parallel or angled to the PCB, provided sufficient space around and/or on the board is included in the system design for proper cable mating and connector space.

3 *Power Supply Information*

Provided the very different needs of the platforms that fit in the small desktop form category, this specification does not attempt to define a standard for the power supply to match with the Mini-ITX motherboard specification. Instead it recommends that manufacturers consider using a:

- SFX, TFX or FlexATX* are available power supply form factor for chassis greater than 4 liters.
- External power adapter for chassis less than 4 liters and All-in-One desktop PCs.**

* Refer to the *microATX Motherboard Interface Specification* for information on power supply requirements.

** Refer to related system design guides for information on AIO power supply requirements.