

# **TFX12V**

## **Thin Form Factor with 12-Volt Connector Power Supply Design Guide**

Version 2.1

---

July, 2005

### **IMPORTANT INFORMATION AND DISCLAIMERS**

INTEL CORPORATION (AND ANY CONTRIBUTOR) IS PROVIDING THIS INFORMATION AS A CONVENIENCE AND ACCORDINGLY MAKES NO WARRANTIES WITH REGARD TO THIS DOCUMENT OR PRODUCTS MADE IN CONFORMANCE WITH THIS DOCUMENT.

THIS DOCUMENT IS PROVIDED "AS IS" AND INTEL DISCLAIMS ALL EXPRESS AND IMPLIED WARRANTIES, INCLUDING THE WARRANTY OF MERCHANTABILITY AND FITNESS FOR PARTICULAR PURPOSE. IN ADDITION, INTEL (AND ANY CONTRIBUTOR) DOES NOT WARRANT OR REPRESENT THAT THIS DOCUMENT OR ANY PRODUCTS MADE IN CONFORMANCE WITH IT WILL OPERATE IN THE INTENDED MANNER, ARE FREE FROM ERRORS OR DEFECTS, OR ARE SAFE FOR USE FOR ITS INTENDED PURPOSE. ANY PERSON USING THIS DOCUMENT OR MAKING, USING, OR SELLING PRODUCTS IN CONFORMANCE WITH THIS DOCUMENT DOES SO AT HIS OR HER OWN RISK.

INTEL DISCLAIMS ALL LIABILITY ARISING FROM OR RELATED TO USE OR IMPLEMENTATION OF THE INFORMATION PROVIDED IN THIS DOCUMENT, INCLUDING LIABILITY FOR INFRINGEMENT OF ANY INTELLECTUAL PROPERTY RIGHTS RELATING TO THE INFORMATION OR THE IMPLEMENTATION OF INFORMATION IN THIS DOCUMENT. INTEL DOES NOT WARRANT OR REPRESENT THAT SUCH DEVICES OR IMPLEMENTATION WILL NOT INFRINGE SUCH RIGHTS.

INTEL IS NOT OBLIGATED TO PROVIDE ANY SUPPORT, INSTALLATION OR OTHER ASSISTANCE WITH REGARD TO THE INFORMATION OR PRODUCTS MADE IN ACCORDANCE WITH IT. THE INFORMATION IN THIS DOCUMENT IS SUBJECT TO CHANGE WITHOUT NOTICE.

THE INFORMATION REFERRED TO IN THIS DOCUMENT IS INTENDED FOR STANDARD COMMERCIAL USE ONLY. CUSTOMERS ARE SOLELY RESPONSIBLE FOR ASSESSING THE SUITABILITY OF THE INFORMATION FOR USE IN PARTICULAR APPLICATIONS. THE INFORMATION IS NOT INTENDED FOR USE IN CRITICAL CONTROL OR SAFETY SYSTEMS, MEDICAL OR LIFE SAVING APPLICATIONS, OR IN NUCLEAR FACILITY APPLICATIONS.

NO LICENSE, EXPRESS OR IMPLIED, BY ESTOPPEL OR OTHERWISE, TO ANY INTELLECTUAL PROPERTY RIGHTS IS GRANTED HEREIN.

Intel and Pentium are registered trademarks of Intel Corporation or its subsidiaries in the United States and other countries.

\* Other names and brands may be claimed as the property of others

Copyright © 2004 Intel Corporation.

# Revision History

Version	Release Date	Notes
1.0	April, 2002	<ul style="list-style-type: none"> <li>Public release</li> </ul>
1.01	May, 2002	<ul style="list-style-type: none"> <li>Added dimension in Figure 5 to clarify location of mounting slot feature</li> </ul>
1.2	April, 2003	<ul style="list-style-type: none"> <li>Updated power and current guidance</li> <li>Added efficiency targets for light and nominal loading</li> <li>Increased minimum Efficiency at full load from 68% to 70%</li> <li>Updated guidance for standby efficiency</li> <li>Added Serial ATA connector</li> <li>Updated Revision history table</li> <li>Reformat title page</li> <li>Added cross loading tables</li> <li>Added loading tables for efficiency measurement points</li> <li>Minor modifications to Energy Star</li> </ul>
2.0	February, 2004	<ul style="list-style-type: none"> <li>Updated power and current guidance</li> <li>Updated cross regulation graphs</li> <li>Updated load tables</li> <li>Updated required efficiency targets. Added recommended efficiency targets. Increased required minimum efficiency at typical and light load.</li> <li>Required Serial ATA connector</li> <li>Added Terminology section</li> <li>Main Power Connector changes to 2x12.</li> <li>Separate current limit on 2x2 connector for 12V2 rail</li> <li>12V2 requirements added</li> </ul>
2.01	June, 2004	<ul style="list-style-type: none"> <li>Updated 3.3 V remote sense pin # on the main power connector</li> <li>Updated 12V2 DC Output Noise/Ripple</li> </ul>
2.1	July, 2005	<ul style="list-style-type: none"> <li>Updated typical power distribution Tables and Figures for 180W, 220W, 240W, 275W.</li> <li>Added 300W PSU related Tables and Figures</li> <li>Updated required efficiency and recommended efficiency targets</li> <li>Added the recommended power supply acoustic targets</li> <li>Protection requirements , Update Product Safety applicable documents and System Safety requirement corrections</li> </ul>

# Contents

---

<b>1</b>	<b>Introduction .....</b>	<b>7</b>
1.1	TFX12V Scope .....	7
1.2	TFX12V Overview .....	7
1.2.1	Small System Optimized Profile .....	7
1.2.2	Improved Acoustics .....	8
1.3	Key Changes for TFX12V Version 2.0 .....	8
1.3.1	Increased +12 VDC Output Capability.....	8
1.3.2	Minimum Efficiency.....	8
1.3.3	Main Power Connector .....	8
1.3.4	Separate Current Limit for 12V2 on the 2x2 Connector .....	8
1.4	Terminology .....	9
<b>2</b>	<b>Electrical .....</b>	<b>10</b>
2.1	AC Input 10	
2.1.1	Input Over Current Protection.....	10
2.1.2	Inrush Current Limiting .....	10
2.1.3	Input Under Voltage.....	10
2.1.4	Regulatory .....	11
2.1.5	Catastrophic Failure Protection .....	12
2.2	DC Output .....	12
2.2.1	DC Voltage Regulation .....	12
2.2.2	Remote Sensing .....	12
2.2.3	Typical Power Distribution .....	13
	Efficiency General .....	17
2.2.4	Other Low Power System Requirements .....	19
2.2.5	Output Ripple/Noise .....	19
2.2.6	Output Transient Response.....	21
2.2.7	Capacitive Load.....	21
2.2.8	Closed-loop Stability.....	21
2.2.9	+5 VDC / +3.3 VDC Power Sequencing .....	22
2.2.10	Voltage Hold-up Time .....	22
2.3	Timing / Housekeeping / Control .....	22
2.3.1	PWR_OK .....	23
2.3.2	PS_ON# .....	23
2.3.3	+5 VSB .....	24
2.3.4	Power-on Time .....	24
2.3.5	Rise Time .....	25
2.3.6	Overshoot at Turn-on / Turn-off.....	25
2.3.7	Reset after Shutdown .....	25
2.3.8	+5 VSB at AC Power-down .....	25
2.4	Output Protection .....	25
2.4.1	Over Voltage Protection .....	25
2.4.2	Short-circuit Protection .....	26
2.4.3	No-load Operation .....	26
2.4.4	Over Current Protection.....	26

	Current protection should be designed to limit the current to operate within safe operating conditions. ....	26
2.4.5	Over-temperature Protection .....	26
2.4.6	Output Bypass .....	26

<b>3</b>	<b>Mechanical .....</b>	<b>27</b>
3.1	Labeling /Marking .....	27
3.2	Physical Dimensions .....	27
3.3	Mounting Options .....	30
3.4	Chassis Requirements .....	31
3.5	Airflow / Fan .....	32
3.6	AC Connector.....	32
3.7	DC Connectors.....	33
3.7.1	TFX12V Main Power Connector.....	34
3.7.2	Peripheral Connector(s) .....	34
3.7.3	Floppy Drive Connector .....	34
3.7.4	+12 V Power Connector .....	35
3.7.5	Serial ATA Power Connector.....	35
<b>4</b>	<b>Environmental .....</b>	<b>36</b>
4.1	Temperature.....	36
4.2	Thermal Shock (Shipping).....	36
4.3	Relative Humidity .....	36
4.4	Altitude Requirement.....	36
4.5	Mechanical Shock .....	36
4.6	Random Vibration .....	37
4.7	Acoustics.....	37
4.8	Ecological Requirements .....	37
<b>5</b>	<b>Safety.....</b>	<b>38</b>
5.1	North America .....	38
5.2	International .....	38
<b>6</b>	<b>Electromagnetic Compatibility .....</b>	<b>39</b>
6.1	Emissions.....	39
6.2	Immunity.....	39
6.3	Input Line Current Harmonic Content .....	40
6.4	Magnetic Leakage Fields .....	40
6.5	Voltage Fluctuations and Flicker .....	40
<b>7</b>	<b>System Cooling Considerations.....</b>	<b>41</b>
<b>8</b>	<b>Reliability .....</b>	<b>41</b>
<b>9</b>	<b>Applicable Documents .....</b>	<b>41</b>

## Figures

Figure 1. TFX12V Power Supply .....	7
Figure 2. Cross Loading Graph for 180W Configuration.....	13
Figure 3. Cross Loading Graph for 220W Configuration.....	14
Figure 4. Cross Loading Graph for 240W Configuration.....	15
Figure 5. Cross Loading Graph for 275W Configuration.....	16
Figure 6. Cross Loading Graph for 300W Configuration.....	17
Figure 7. Differential Noise Test Setup .....	20
Figure 8. Power Supply Timing.....	22
Figure 9. PS_ON# Signal Characteristics.....	24
Figure 10. Power Supply Dimensions and Recommended Feature Placements (not to scale).28	
Figure 11. Power Supply Mounting Slot Detail .....	29
Figure 12. Fan Right and Fan Left Orientations of Power Supply in a Chassis.....	30
Figure 13. Suggested TFX12V Chassis Cutout.....	31
Figure 14. Suggested Mounting Tab (chassis feature).....	31
Figure 15. TFX12V Connectors (Pin-side view, not to scale) .....	33
Figure 16. Serial ATA Connector .....	35

## Tables

Table 1. AC Input Line Requirements .....	10
Table 2. DC Output Voltage Regulation.....	12
Table 3. Typical Power Distribution for 180 W TFX12V Configurations .....	13
Table 4. Typical Power Distribution for 220 W TFX12V Configurations .....	14
Table 5. Typical Power Distribution for 240 W TFX12V Configurations .....	15
Table 6. Typical Power Distribution for 275 W TFX12V Configurations .....	16
Table 7. Typical Power Distribution for 300 W TFX12V Configurations .....	17
Table 8. Efficiency Vs Load .....	18
Table 9. Loading Table for Efficiency Measurements.....	18
Table 10. Energy Star Input Power Consumption.....	19
Table 11. DC Output Noise/Ripple.....	19
Table 12. DC Output Transient Step Sizes.....	21
Table 13. Output Capacitive Loads.....	21
Table 14. PWR_OK Signal Characteristics.....	23
Table 15. PS_ON# Signal Characteristics .....	24
Table 16. Over Voltage Protection.....	26
Table 17. Recommended power supply acoustic targets .....	37

# 1 Introduction

---

## 1.1 TFX12V Scope

This document provides design suggestions for a small form factor power supply that is primarily intended for use with small form factor system designs (9-15 liters in total system volume). It should not be inferred that all Thin Form Factor with 12 Volt connector (TFX12V) power supplies must conform exactly to the content of this document, though there are key parameters that define mechanical fit across a common set of platforms. Since power supply needs vary depending on system configuration, the design specifics described are not intended to support all possible systems.

---

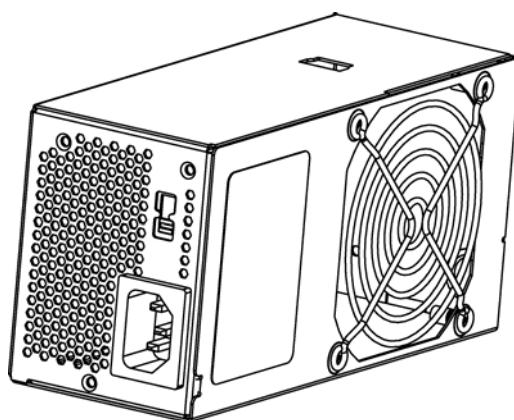

Figure 1. TFX12V Power Supply

---

## 1.2 TFX12V Overview

This section provides a brief overview of the unique features of the Thin Form Factor with 12 Volt connector (TFX12V) power supply design and a summary of the changes included in revision 1.2.

### 1.2.1 Small System Optimized Profile

The increase in demand for smaller systems results in unique system layout challenges. The Thin Form Factor with 12 Volt connector (TFX12V) configuration has been optimized for small and low profile microATX and FlexATX system layouts. The long narrow profile of the power supply (shown in Figure 1) fits easily into low profile systems. The fan placement can be used to efficiently exhaust air from the processor and core area of the motherboard, making possible smaller, more efficient systems using common industry ingredients.

## 1.2.2 Improved Acoustics

As desktop systems become smaller, they are placed in more exposed areas in the home and work place. The smaller systems are no longer confined to the floor or under the desk, but are placed on the desktop next to the user. In these situations, noise becomes an important factor to the end user. Thin Form Factor with 12 Volt connector (TFX12V) supplies should use fan speed control techniques to provide a low acoustic profile, while providing ample cooling to internal components when required.

## 1.3 Key Changes for TFX12V Version 2.0

This section briefly summarizes the major changes made to this document that now defines TFX12V power supply. With the move to 12V voltage regulators for the processor, TFX guidelines for 5V as main power are no longer provided.

### 1.3.1 Increased +12 VDC Output Capability

System components that use 12V are continuing to increase in power. In cases where expected current requirements is greater than 18A a second 12 V rail should be made available. The TFX12V power supplies should be designed to accommodate these increased +12 VDC currents.

### 1.3.2 Minimum Efficiency

Minimum measured efficiency is required to be 70% at full, 72% at typical (50%) load and 65% at light (20%) load. New recommended guidance has been added to provide direction for expected future requirements.

### 1.3.3 Main Power Connector

The 2 x 12 main power connector replaces the 2 x 10 connector. This change was made to support 75 watt PCI Express\* requirements.

### 1.3.4 Separate Current Limit for 12V2 on the 2x2 Connector

It is recommended that the 12V rail on the 2 x 2 power connector be a separate current limited output to help meet the system requirements of UL and EN 60950.

## 1.4 Terminology

The following terms are used in this document:

Term	Description
<b>Required</b>	The status given to items within this design guide, which are required to meet design guide and a large majority of system applications.
<b>Recommended</b>	The status given to items within this design guide, which are not required to meet design guide, however, are required by many system applications.
<b>Optional</b>	The status given to items within this design guide, which are not required to meet design guide, however, some system applications may optionally use these features.
<b>B<sub>A</sub></b>	Declared sound power, LwAd. The declared sound power level shall be measured according to ISO* 7779 for the power supply and reported according to ISO 9296.
<b>CFM</b>	Cubic Feet per Minute (airflow).
<b>Monotonically</b>	A waveform changes from one level to another in a steady fashion, without intermediate retracement or oscillation.
<b>Noise</b>	The periodic or random signals over frequency band of 0 Hz to 20 MHz.

## 2 Electrical

---

The following electrical requirements must be met over the environmental ranges as defined in Section 5 (unless otherwise noted).

### 2.1 AC Input

Table 1, lists AC input voltage and frequency requirements for continuous operation. The power supply shall be capable of supplying full-rated output power over two input voltage ranges rated 100-127 VAC and 200-240 VAC rms nominal. The correct input range for use in a given environment may be either switch-selectable or auto-ranging. The power supply shall automatically recover from AC power loss. The power supply must be able to start up under peak loading at 90 VAC.

**Table 1. AC Input Line Requirements**

Parameter	Minimum	Nominal*	Maximum	Unit
$V_{in}$ (115 VAC)	90	115	135	VAC <sub>rms</sub>
$V_{in}$ (230 VAC)	180	230	265	VAC <sub>rms</sub>
$V_{in}$ Frequency	47	--	63	Hz

\*Note: Nominal voltages for test purposes are considered to be within  $\pm 1.0$  V of nominal.

#### 2.1.1 Input Over Current Protection

The power supply shall incorporate primary fusing for input over current protection to prevent damage to the power supply and meet product safety requirements. Fuses should be slow-blow-type or equivalent to prevent nuisance trips.<sup>1</sup>

#### 2.1.2 Inrush Current Limiting

Maximum inrush current from power-on (with power-on at any point on the AC sine) and including, but not limited to, three line cycles, shall be limited to a level below the surge rating of the input line cord, AC switch if present, bridge rectifier, fuse, and EMI filter components. Repetitive ON/OFF cycling of the AC input voltage should not damage the power supply or cause the input fuse to blow.

#### 2.1.3 Input Under Voltage

The power supply shall contain protection circuitry such that the application of an input voltage below the minimum specified in Section 2.1, Table 1, shall not cause damage to the power supply.

---

<sup>1</sup> For Denmark and Switzerland international safety requirements, if the internal over current protective devices exceed 8A for Denmark and 10A for Switzerland, then the power supply must pass international safety testing to EN 60950 using a maximum 16A over-current protected branch circuit, and this 16A (time delay fuse) branch circuit protector must not open during power supply abnormal operation (output short circuit and component fault) testing.

## 2.1.4 Regulatory

The power supply should comply to the most recent version of the following regulatory requirements and/or standards as appropriate for the target market.

### 2.1.4.1 PRODUCT SAFETY

UL 60950-1, First Edition (2003) –CAN/CSA-C22.2-60950-1-03 First Edition,

EN 60950-1:2001 + Amendments A11:2004,

IEC 60950-1: 2001 + Amendments and National Deviations, EU Low Voltage Directive (73/23/EEC) (CE Compliance)

GB4943-2001 (China)

CNS 14336: 2004 (Taiwan BSMI)

### 2.1.4.2 ELECTROMAGNETIC COMPATIBILITY

FCC, Class B, Part 15 (Radiated & Conducted Emissions)

CISPR 22 / EN55022, (Radiated & Conducted Emissions)

EN55024 (ITE Specific Immunity)

EN 61000-4-2 – Electrostatic Discharge

EN 61000-4-3– Radiated RFI Immunity

EN 61000-4-4– Electrical Fast Transients.

EN 61000-4-5 – Electrical Surge

EN 61000-4-6 – RF Conducted

EN 61000-4-8 – Power Frequency Magnetic Fields

EN 61000-4-11 – Voltage Dips, Short Interrupts and Fluctuations

EN61000-3-2 (Harmonics)

EN61000-3-3 (Voltage Flicker)

EU EMC Directive ((8/9/336/EEC) (CE Compliance)

### 2.1.4.3 Other Certifications and/or Declarations

GB925 (China/CCC\*)

CNS13438 (Taiwan/BSMI\*)

AS/NZ3548 (Australia/C-tick\* based on CISPR22)

## 2.1.5 Catastrophic Failure Protection

Should a component failure occur, the power supply should not exhibit any of the following:

- Flame
- Excessive smoke
- Charred PCB
- Fused PCB conductor
- Startling noise
- Emission of molten material
- Earth ground fault (short circuit to ground or chassis enclosure)

## 2.2 DC Output

### 2.2.1 DC Voltage Regulation

The DC output voltages shall remain within the regulation ranges shown in Table 2, when measured at the load end of the output connectors under all line, load, and environmental conditions. The voltage regulation limits shall be maintained under continuous operation for any steady state temperature and operating conditions specified in Section 4.

**Table 2. DC Output Voltage Regulation**

Output	Range	Minimum	Nominal	Maximum	Unit
+12 V1DC <sup>1</sup>	±5%	+11.40	+12.00	+12.60	Volts
+12 V2DC <sup>3</sup>	±5%	+11.40	+12.00	+12.60	Volts
+5 VDC	±5%	+4.75	+5.00	+5.25	Volts
+3.3 VDC <sup>2</sup>	±5%	+3.14	+3.30	+3.47	Volts
-12 VDC	±10%	-10.80	-12.00	-13.20	Volts
+5 VSB	±5%	+4.75	+5.00	+5.25	Volts

**Note:** <sup>(1)</sup> At +12 VDC peak loading, regulation at the +12 V1DC output can go to ± 10%.

<sup>(2)</sup> Voltage tolerance is required at main connector and S-ATA connector (if used).

<sup>(3)</sup> Minimum voltage during peak is greater than 11.0 VDC.

### 2.2.2 Remote Sensing

The +3.3 VDC output should have provisions for remote sensing to compensate for excessive cable drops. The default sense should be connected to pin 13 of the main power connector. The power supply should draw no more than 10 mA through the remote sense line to keep DC offset voltages to a minimum.

### 2.2.3 Typical Power Distribution

DC output power requirements and distributions will vary based on specific system options and implementation.

Significant dependencies include the quantity and types of processors, memory, add-in card slots, and peripheral bays, as well as support for advanced graphics or other features. Table 3 through Table 7 shows the power distribution and cross loading tables for power supplies in the range of 180 W to 300 W. *It is ultimately the responsibility of the designer to define a power budget for a given target product and market.*

**Table 3. Typical Power Distribution for 180 W TFX12V Configurations**

Output	Minimum Current (amps)	Rated Current (amps)	Peak Current (amps)
+12 VDC	1.0	13.0	15.0
+5 VDC	0.3	12.0 (Note)	
+3.3 VDC	0.5	9.0 (Note)	
-12 VDC	0.0	0.3	
+5 VSB	0.0	2.0	2.5

**Note:** Total combined output of 3.3 V and 5 V is  $\leq 63$  W

Peak currents may last up to 17 seconds with not more than one occurrence per minute

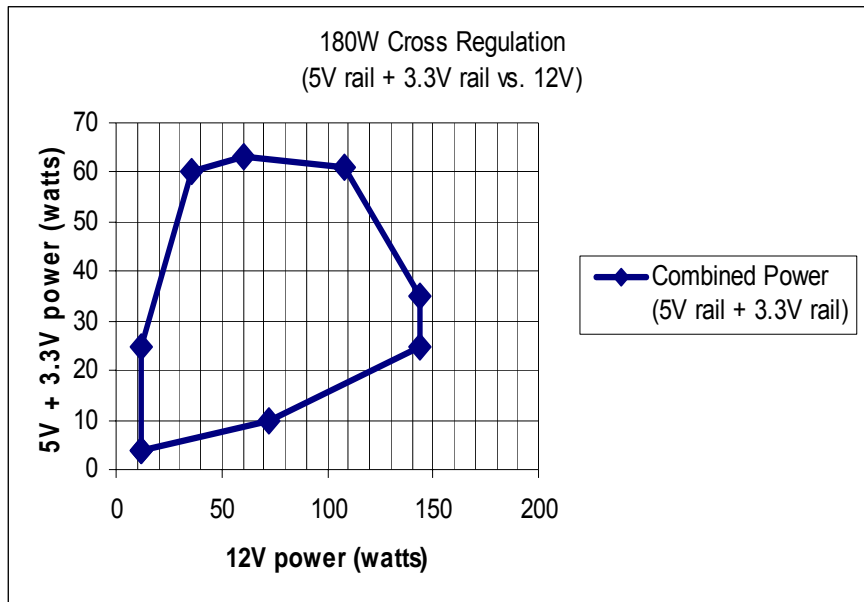

**Figure 2. Cross Loading Graph for 180W Configuration**

**Table 4. Typical Power Distribution for 220 W TFX12V Configurations**

Output	Minimum Current (amps)	Rated Current (amps)	Peak Current (amps)
+12 VDC	1.0	15.0	17.0
+5 VDC	0.3	12.0 (Note)	
+3.3 VDC	0.5	12.0 (Note)	
-12 VDC	0.0	0.3	
+5 VSB	0.0	2.0	2.5

**Note:** Total combined output of 3.3 V and 5 V is  $\leq 100$  W

Peak currents may last up to 17 seconds with not more than one occurrence per minute

**Figure 3. Cross Loading Graph for 220W Configuration**

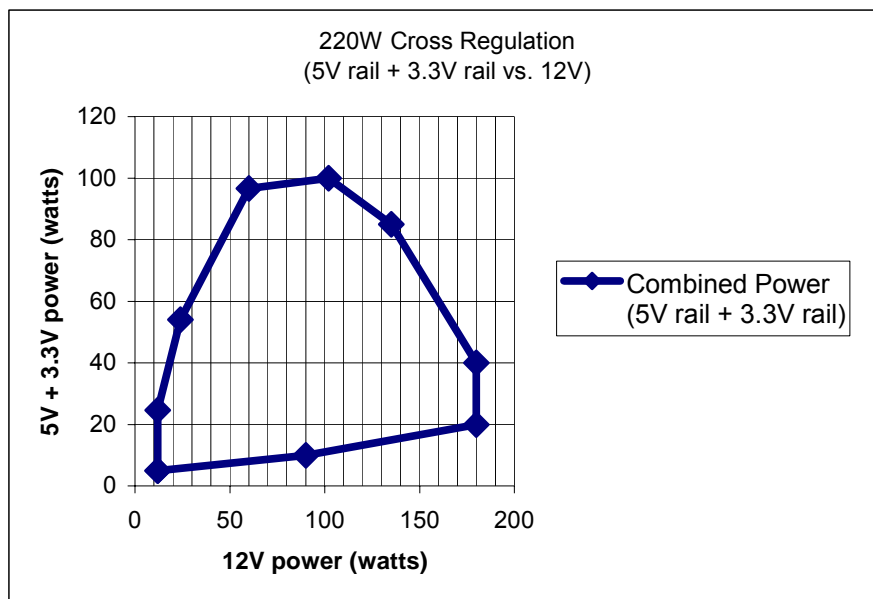
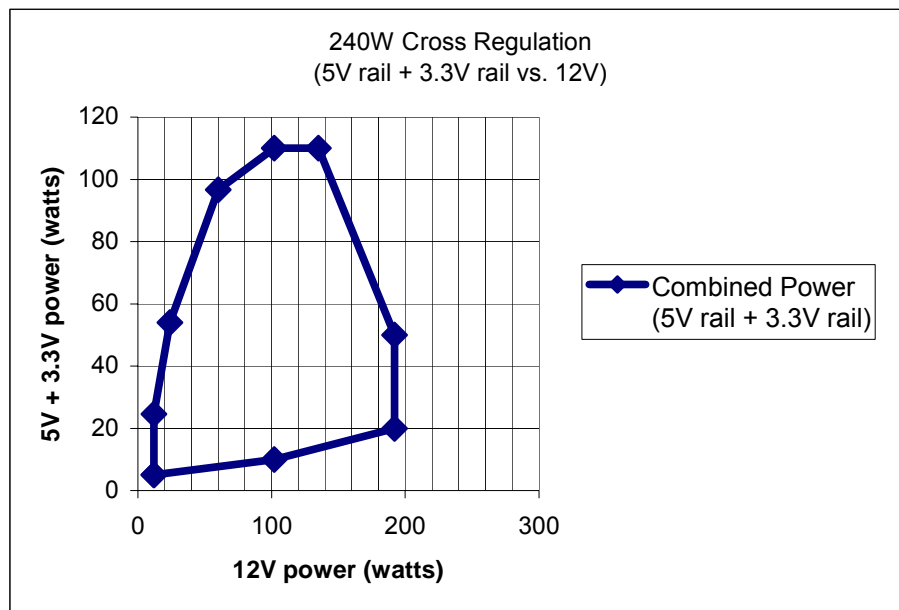

**Table 5. Typical Power Distribution for 240 W TFX12V Configurations**

Output	Minimum Current (amps)	Rated Current (amps)	Peak Current (amps)
+12 VDC	1.0	16.0	18.0
+5 VDC	0.3	12.0 (Note)	
+3.3 VDC	0.5	14.0 (Note)	
-12 VDC	0.0	0.3	
+5 VSB	0.0	2.0	2.5

**Note:** Total combined output of 3.3 V and 5 V is  $\leq 110$  W

Peak currents may last up to 17 seconds with not more than one occurrence per minute



**Figure 4. Cross Loading Graph for 240W Configuration**

**Table 6: Typical Power Distribution for 275 W TFX12V Configurations**

Output	Minimum Current (amps)	Maximum Current (amps)	Peak Current (amps)
+12 V1DC <sup>(1,2)</sup>	1.0	5.0	6.0
+12 V2DC <sup>(2,3)</sup>	1.0	13.0	16.5
+5 VDC	0.3	12.0	
+3.3 VDC	0.5	16	
-12 VDC	0.0	0.3	
+5 VSB <sup>(1)</sup>	0.0	2.0	2.5

Note: Total combined output of 3.3 V and 5 V is  $\leq 110$  W

<sup>(1)</sup> Peak currents may last up to 17 seconds with not more than one occurrence per minute

<sup>(2)</sup> 12V1 and 12V2 should have separate current limit circuits

<sup>(3)</sup> 12V2 supports processor power requirements and must have a separate current limit. 16.5 Ampere peak current can last for 10 ms, minimum voltage during peak is  $> 11.0$  VDC.

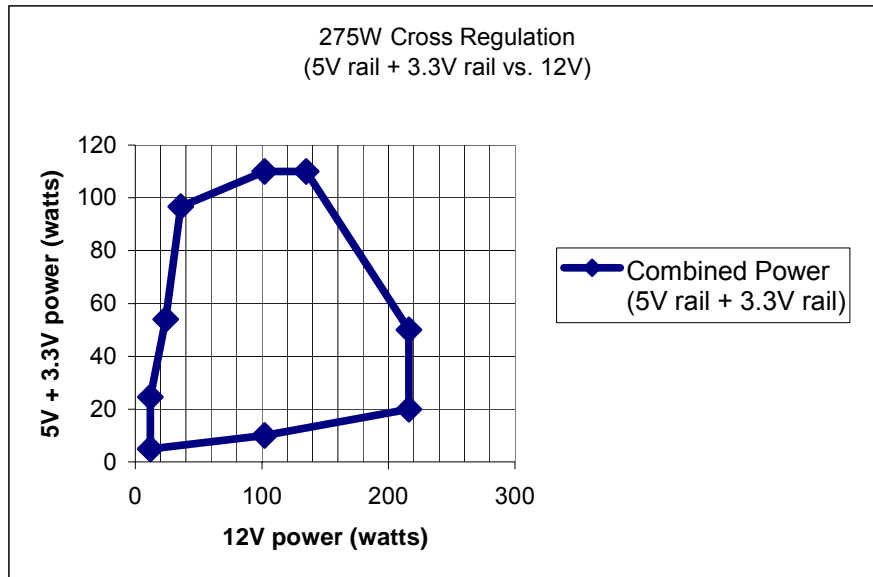

**Figure 5 Cross Loading Graph for 275W Configuration**

**Table 7: Typical Power Distribution for 300 W TFX12V Configurations**

Output	Minimum Current (amps)	Maximum Current (amps)	Peak Current (amps)
+12 V1DC <sup>(1,2)</sup>	1.0	6.0	7.0
+12 V2DC <sup>(2,3)</sup>	1.0	16.0	19.0
+5 VDC	0.5	12.0	
+3.3 VDC	0.5	20.0	
-12 VDC	0.0	0.3	
+5 VSB <sup>(1)</sup>	0.0	2.0	2.5

Note: Total combined output of 3.3 V and 5 V is  $\leq 110$  W

- <sup>(1)</sup> Peak current may last up to 17 seconds with not more than one occurrence per minute
- <sup>(2)</sup> 12V1DC and 12V2DC should have separate current limit circuits
- <sup>(3)</sup> 12V2DC support processor power requirements and must have a separate current limit. 19Ampere peak current can last for 10 ms, minimum voltage during peak is > 11.0 VDC.

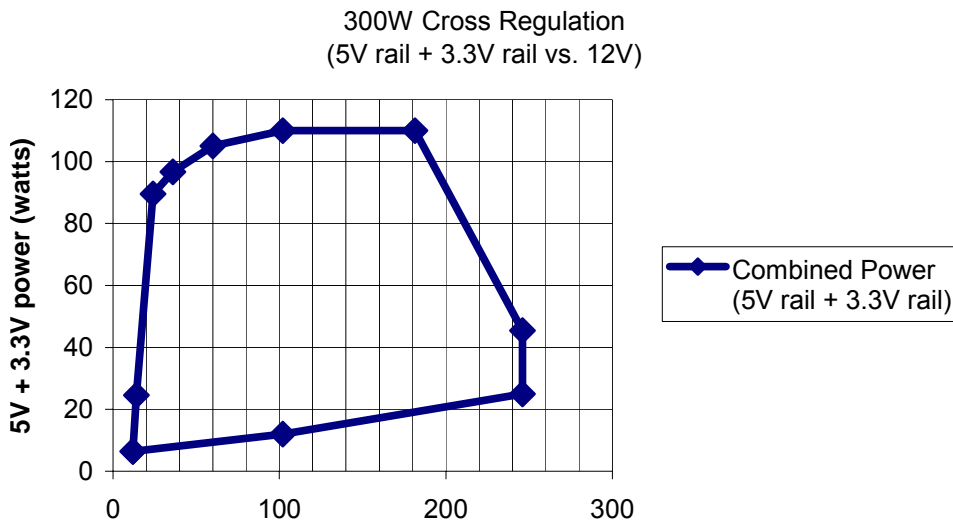

**Figure 6 Cross Loading Graph for 300W Configuration Efficiency General**

The power supply should be a minimum of 70% efficient under “Full” load, 72% under “typical” load, and 65% in a “light” load idle condition. The efficiency of the power supply should be tested at nominal input voltage of 115VAC input and 230VAC input, under the load conditions defined in Table 9 , and under the temperature and operating conditions defined in Section 3. The loading condition for testing efficiency shown in Table 8 represents a fully loaded system, a typical (50%) loaded system, and a light (20%) loaded system.

**Table 8: Efficiency Vs Load**

Loading	Full load	Typical load	Light load
Required Minimum Efficiency	70%	72%	65%
Recommended Minimum Efficiency	77%	80%	75%

**Table 9: Loading Table for Efficiency Measurements**

180W (loading shown in Amps)						
Loading	+12V	+5V	+3.3V	-12V	+5Vsb	
Full	9.1	8.4	6.3	0.2	1.0	
Typical	4.6	4.2	3.2	0.1	1.0	
Light	1.8	1.7	1.3	0.0	1.0	
220W (loading shown in Amps)						
Loading	+12V	+5V	+3.3V	-12V	+5Vsb	
Full	11.4	9.1	9.1	0.2	1.0	
Typical	5.7	4.6	4.6	0.1	1.0	
Light	2.3	1.8	1.8	0.0	1.0	
240W (loading shown in Amps)						
Loading	+12V	+5V	+3.3V	-12V	+5Vsb	
Full	12.5	9.3	10.9	0.2	1.0	
Typical	6.2	4.7	5.5	0.1	1.0	
Light	2.5	1.9	2.2	0.0	1.0	
275W (loading shown in Amps)						
Loading	+12V1	+12V2	+5V	+3.3V	-12V	+5Vsb
Full	4.1	10.6	9.7	13.0	0.2	1.0
Typical	2	5.3	4.9	6.5	0.1	1.0
Light	0.8	2.1	1.9	2.6	0.0	1.0
300W (loading shown in Amps)						
Loading	+12V1	+12V2	+5V	+3.3V	-12V	+5Vsb
Full	4.5	12.0	9.0	15.0	0.2	1.0
Typical	2.2	6.0	4.5	7.5	0.1	1.0

Light	0.9	2.4	1.8	3.0	0	1.0
-------	-----	-----	-----	-----	---	-----

### 2.2.3.1 Energy Star\*

The “Energy Star” efficiency requirements of the power supply depend on the intended system configuration. In the low power / sleep state (S1 or S3) the system should consume power in accordance with the values listed in Table 10.

**Table 10: Energy Star Input Power Consumption**

Maximum Continuous Power Rating of Power Supply	RMS Watts from the AC Line in Sleep/low-Power Mode
$\leq 200$ W	$\leq 15$ W
$> 200$ W $\leq 300$ W	$\leq 20$ W
$> 300$ W $\leq 350$ W	$\leq 25$ W
$> 350$ W $\leq 400$ W	$\leq 30$ W
$> 400$ W	10% of the maximum continuous output rating

**Note:** To help meet the “Energy Star” system requirements, it is recommended that the power supply have  $> 50\%$  efficiency in standby mode.

### 2.2.4 Other Low Power System Requirements

To help meet the Blue Angel\* system requirements, RAL-UZ 78, US Presidential executive order 13221, future EPA requirements, and other low Power system requirements, it is recommended that the +5 VSB standby supply efficiency should be as high as possible. Standby efficiency is measured with the main outputs off (PS\_ON# high state). Standby efficiency should be greater than 50% with a load of 100mA.

### 2.2.5 Output Ripple/Noise

The output ripple/noise requirements listed in Table 11 should be met throughout the load ranges specified in Section 2.2.3 and under all input voltage conditions as specified in Section 3.1.

Ripple and noise are defined as periodic or random signals over a frequency band of 10 Hz to 20 MHz. Measurements shall be made with an oscilloscope with 20 MHz of bandwidth. Outputs should be bypassed at the connector with a 0.1 $\mu$ F ceramic disk capacitor and a 10 $\mu$ F electrolytic capacitor to simulate system loading. See Figure 7.

**Table 11: DC Output Noise/Ripple**

Output	Maximum Ripple and Noise (mVpp)
+12 V1DC	120
+12 V2DC	120
+5 VDC	50
+3.3 VDC	50

-12 VDC	120
+5 VSB	50

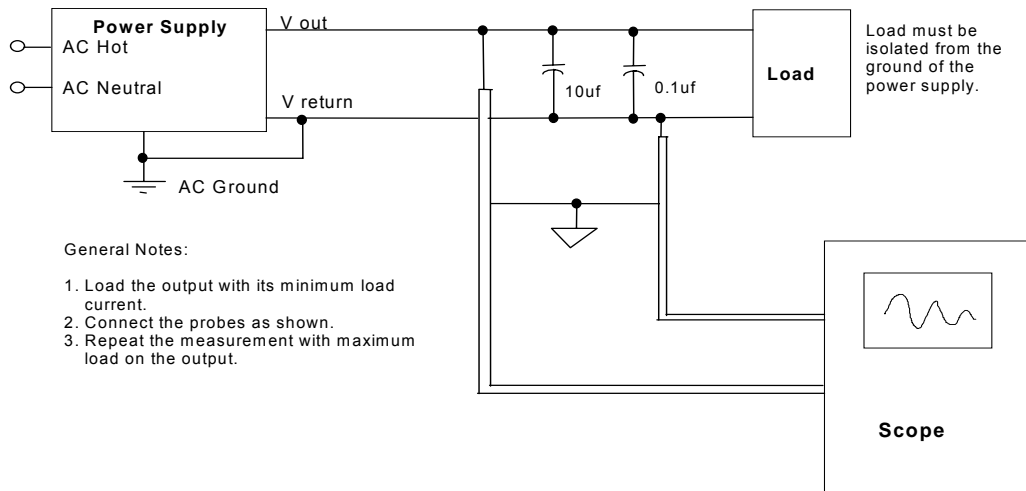

Filter Note:

0.1µf - Kemet, C1206C104K5RAC or equivalent  
10µf - United Chemi-con, 293D106X0025D2T or equivalent

Scope Note:

Use Tektronix† TDS460 Oscilloscope or equivalent and a P6046 probe or equivalent.

**Figure 7. Differential Noise Test Setup**

## 2.2.6 Output Transient Response

Table 12 summarizes the expected output transient step sizes for each output. The transient load slew rate is = 1.0 A/ $\mu$ s.

**Table 12: DC Output Transient Step Sizes**

Output	Maximum Step Size (% of rated output amps)	Maximum Step Size (amps)
+12 V1DC	40%	
+12 V2DC	60%	
+5 VDC	30%	
+3.3 VDC	30%	
-12 VDC		0.1 A
+5 VSB		0.5 A

Note: For example, for a rated +5 VDC output of 14 A, the transient step would be 30%  $\times$  14 A = 4.2 A

Output voltages should remain within the regulation limits of Table 2, Section 2.2.1, for instantaneous changes in load as specified in Table 12 and for the following conditions:

- Simultaneous load steps on the +12 VDC, +5 VDC, and +3.3 VDC outputs (all steps occurring in the same direction)
- Load-changing repetition rate of 50 Hz to 10 kHz
- AC input range per Section 2.1 and Capacitive loading per Table 13.

## 2.2.7 Capacitive Load

The power supply should be able to power up and operate with the regulation limits defined in Table 2, Section 2.2.1, with the following capacitances simultaneously present on the DC outputs.

**Table 13: Output Capacitive Loads**

Output	Capacitive Load ( $\mu$ F)
+12 V1DC	5,000
+12 V2DC	3,000
+5 VDC	10,000
+3.3 VDC	6,000
-12 VDC	350
+5 VSB	350

## 2.2.8 Closed-loop Stability

The power supply shall be unconditionally stable under all line/load/transient load conditions including capacitive loads specified in Section 2.2.7. A minimum of 45 degrees phase margin and 10 dB gain margin is recommended at both the maximum and minimum loads.

## 2.2.9 +5 VDC / +3.3 VDC Power Sequencing

The +12 VDC and +5 VDC output levels must be equal to or greater than the +3.3 VDC output at all times during power-up and normal operation. The time between the +12 VDC or +5 VDC output reaching its minimum in-regulation level and +3.3 VDC reaching its minimum in-regulation level must be  $\leq 20$  ms.

## 2.2.10 Voltage Hold-up Time

The power supply should maintain output regulations per Section 2.2.1 despite a loss of input power at the low-end nominal range—115 VAC / 47 Hz or 230 VAC / 47 Hz - at maximum continuous output load as applicable for a minimum of 17 ms.

## 2.3 Timing / Housekeeping / Control

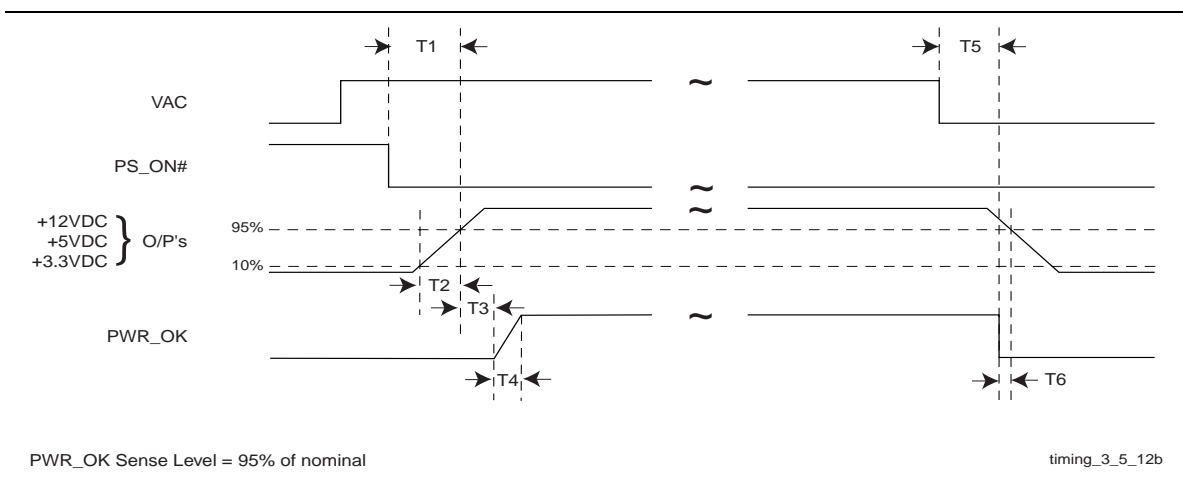

**Figure 8. Power Supply Timing**

Notes: T1 is defined in Section 2.3.4. , T2 in Section 2.3.5. T3, T4, T5, and T6 are defined in Table 14.

### 2.3.1 PWR\_OK

PWR\_OK is a “power good” signal. This signal should be asserted high by the power supply to indicate that the +12 VDC, +5 VDC, and +3.3 VDC outputs are above the under voltage thresholds listed in Table 2 in Section 2.2.1 and that sufficient mains energy is stored by the converter to guarantee continuous power operation within specification for at least the duration specified in Section 2.2.10, “Voltage Hold-up Time.” Conversely, PWR\_OK should be de-asserted to a low state when any of the +12 VDC, +5 VDC, or +3.3 VDC output voltages falls below its under voltage threshold, or when mains power has been removed for a time sufficiently long such that power supply operation cannot be guaranteed beyond the power-down warning time. The electrical and timing characteristics of the PWR\_OK signal are given in Table 14 and in Figure 8.

**Table 14: PWR\_OK Signal Characteristics**

Signal Type	+5 V TTL compatible
Logic level low	< 0.4 V while sinking 4 mA
Logic level high	Between 2.4 V and 5 V output while sourcing 200 $\mu$ A
High-state output impedance	1 k $\Omega$ from output to common
PWR_OK delay	100 ms < $T_3$ < 500 ms
PWR_OK rise time	$T_4 \leq 10$ ms
AC loss to PWR_OK hold-up time	$T_5 \geq 16$ ms
Power-down warning	$T_6 \geq 1$ ms

### 2.3.2 PS\_ON#

PS\_ON# is an active-low, TTL-compatible signal that allows a motherboard to remotely control the power supply in conjunction with features such as soft on/off, Wake on LAN\*, or wake-on-modem. When PS\_ON# is pulled to TTL low, the power supply should turn on the four main DC output rails: +12 VDC, +5 VDC, +3.3 VDC, and -12 VDC. When PS\_ON# is pulled to TTL high or open-circuited, the DC output rails should not deliver current and should be held at zero potential with respect to ground. PS\_ON# has no effect on the +5 VSB output, which is always enabled whenever the AC power is present. Table 15 lists PS\_ON# signal characteristics.

The power supply shall provide an internal pull-up to TTL high. The power supply shall also provide de-bounce circuitry on PS\_ON# to prevent it from oscillating on/off at startup when activated by a mechanical switch. The DC output enable circuitry must be SELV-compliant.

The power supply shall not latch into a shutdown state when PS\_ON# is driven active by pulses between 10ms to 100ms during the decay of the power rails.

**Table 15: PS\_ON# Signal Characteristics**

Parameter	Minimum	Maximum
$V_{IL}$ , Input Low Voltage	0.0 V	0.8 V
$I_{IL}$ , Input Low Current ( $V_{in} = 0.4$ V)		-1.6 mA
$V_{IH}$ , Input High Voltage ( $I_{in} = -200$ $\mu$ A)	2.0 V	
$V_{IH}$ open circuit, $I_{in} = 0$		5.25 V

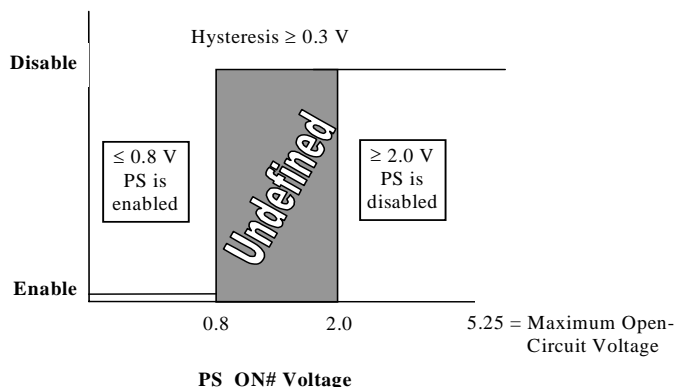

**Figure 9. PS\_ON# Signal Characteristics**

### 2.3.3 +5 VSB

+5 VSB is a standby supply output that is active whenever the AC power is present. This output provides a power source for circuits that must remain operational when the five main DC output rails are in a disabled state. Example uses include soft power control, Wake on LAN, wake-on-modem, intrusion detection, or suspend state activities.

The +5 VSB output should be capable of delivering a minimum of 2.0 A. at  $+5$  V  $\pm$  5% to external circuits. The power supply must be able to provide the required power during a "wake up" event. If an external USB device generates the event, there may be peak currents as high as 2.5 A., lasting no more than 500 ms.

Over current protection is required on the +5 VSB output regardless of the output current rating. This ensures the power supply will not be damaged if external circuits draw more current than the supply can provide.

### 2.3.4 Power-on Time

The power-on time is defined as the time from when PS\_ON# is pulled low to when the +12 VDC, +5 VDC, and +3.3 VDC outputs are within the regulation ranges specified in Section 2.2.1. The power-on time shall be less than 500 ms ( $T_1 < 500$  ms).

+5 VSB shall have a power-on time of two seconds *maximum* after application of valid AC voltages.

### 2.3.5 Rise Time

The output voltages shall rise from  $\leq 10\%$  of nominal to within the regulation ranges specified in Section 2.2.1 within 0.2 ms to 20 ms ( $0.2 \text{ ms} \leq T_2 \leq 20 \text{ ms}$ ).

There must be a smooth and continuous ramp of each DC output voltage from 10% to 90% of its final set point within the regulation band, while loaded as specified in Section 2.2.1.

The smooth turn-on requires that, during the 10% to 90% portion of the rise time, the slope of the turn-on waveform must be positive and have a value of between 0 V/ms and  $[V_{\text{out, nominal}} / 0.1]$  V/ms. Also, for any 5 ms segment of the 10% to 90% rise time waveform, a straight line drawn between the end points of the waveform segment must have a slope  $\geq [V_{\text{out, nominal}} / 20]$  V/ms.

### 2.3.6 Overshoot at Turn-on / Turn-off

The output voltage overshoot upon the application or removal of the input voltage, or the assertion/de-assertion of PS\_ON#, under the conditions specified in Section 2.3.2, shall be less than 10% above the nominal voltage. No voltage of opposite polarity shall be present on any output during turn-on or turn-off.

### 2.3.7 Reset after Shutdown

If the power supply latches into a shutdown state because of a fault condition on its outputs, the power supply shall return to normal operation only after the fault has been removed and the PS\_ON# has been cycled OFF/ON with a minimum OFF time of one second.

### 2.3.8 +5 VSB at AC Power-down

After AC power is removed, the +5 VSB standby voltage output should remain at its steady state value for the minimum hold-up time specified in Section 2.2.10 until the output begins to decrease in voltage. The decrease shall be monotonic in nature, dropping to 0.0 V. There shall be no other disturbances of this voltage at or following removal of AC power.

## 2.4 Output Protection

### 2.4.1 Over Voltage Protection

The over voltage sense circuitry and reference shall reside in packages that are separate and distinct from the regulator control circuitry and reference. No single point fault shall be able to cause a sustained over voltage condition on any or all outputs. The supply shall provide latch-mode over voltage protection as defined in Table 16.

**Table 16: Over Voltage Protection**

Output	Minimum	Nominal	Maximum	Unit
+12 V1DC	13.4	15.0	15.6	Volts
+12 V2DC	13.4	15.0	15.6	Volts
+5 VDC	5.74	6.3	7.0	Volts
+3.3 VDC	3.76	4.2	4.3	Volts

## 2.4.2 Short-circuit Protection

An output short circuit is defined as any output impedance of less than 0.1 ohms. The power supply shall shut down and latch off for shorting the +3.3 VDC, +5 VDC, or +12 VDC rails to return or any other rail. The +12V1DC and 12V2 DC should have separate short circuit and overload protection. Shorts between main output rails and +5 VSB shall not cause any damage to the power supply. The power supply shall either shut down and latch off or fold back for shorting the negative rails. +5 VSB must be capable of being shorted indefinitely, but when the short is removed, the power supply shall recover automatically or by cycling PS\_ON#. The power supply shall be capable of withstanding a continuous short circuit to the output without damage or overstress to the unit (for example, to components, PCB traces, and connectors) under the input conditions specified in Section 2.1

## 2.4.3 No-load Operation

No damage or hazardous condition should occur with all the DC output connectors disconnected from the load. The power supply may latch into the shutdown state.

## 2.4.4 Over Current Protection

Current protection should be designed to limit the current to operate within safe operating conditions.

## 2.4.5 Over-temperature Protection

As an option, the power supply may include an over-temperature protection sensor, which can trip and shut down the power supply at a preset temperature point. Such an overheated condition is typically the result of internal current overloading or a cooling fan failure. If the protection circuit is non-latching, then it should have hysteresis built in to avoid intermittent tripping.

## 2.4.6 Output Bypass

The output return may be connected to the power supply chassis, and will be connected to the system chassis by the system components.

## 3 Mechanical

---

### 3.1 Labeling /Marking

The following is a non-inclusive list of suggested markings for each power supply unit. Product regulation stipulations for sale into various geographies may impose additional labeling requirements.

- Manufacturer information: manufacturer's name, part number and lot date code, etc., in human-readable text and/or bar code formats
- Nominal AC input operating voltages (100-127 VAC and 200-240 VAC) and current rating certified by all applicable safety agencies
- DC output voltages and current ratings
- Access warning text ("Do not remove this cover. Trained service personnel only. No user serviceable components inside.") must be in English, German, Spanish, French, Chinese, and Japanese with universal warning markings

### 3.2 Physical Dimensions

The power supply shall be enclosed and meet the physical outline shown in Figure 10, as applicable.

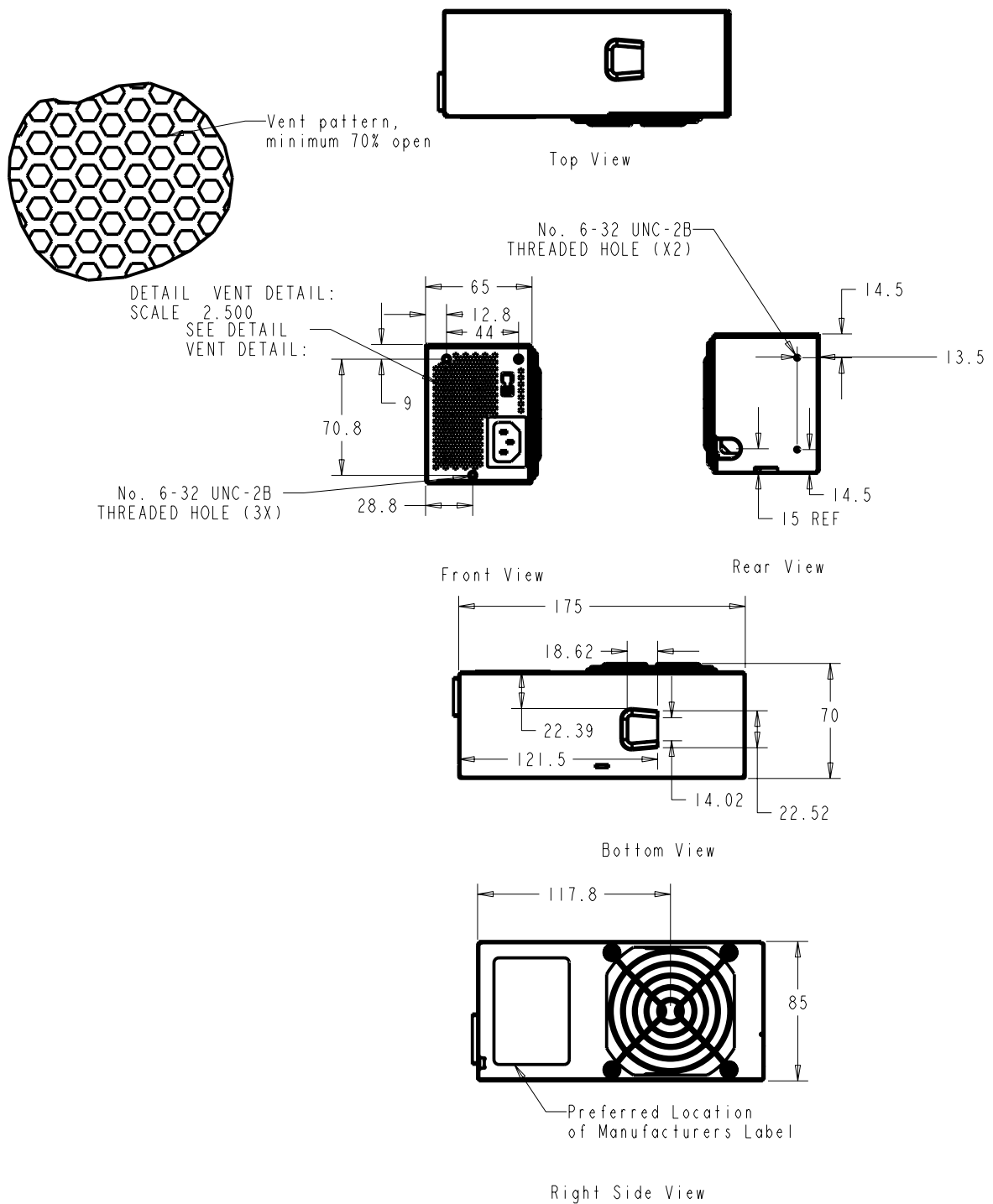

**Figure 10. Power Supply Dimensions and Recommended Feature Placements (not to scale)**

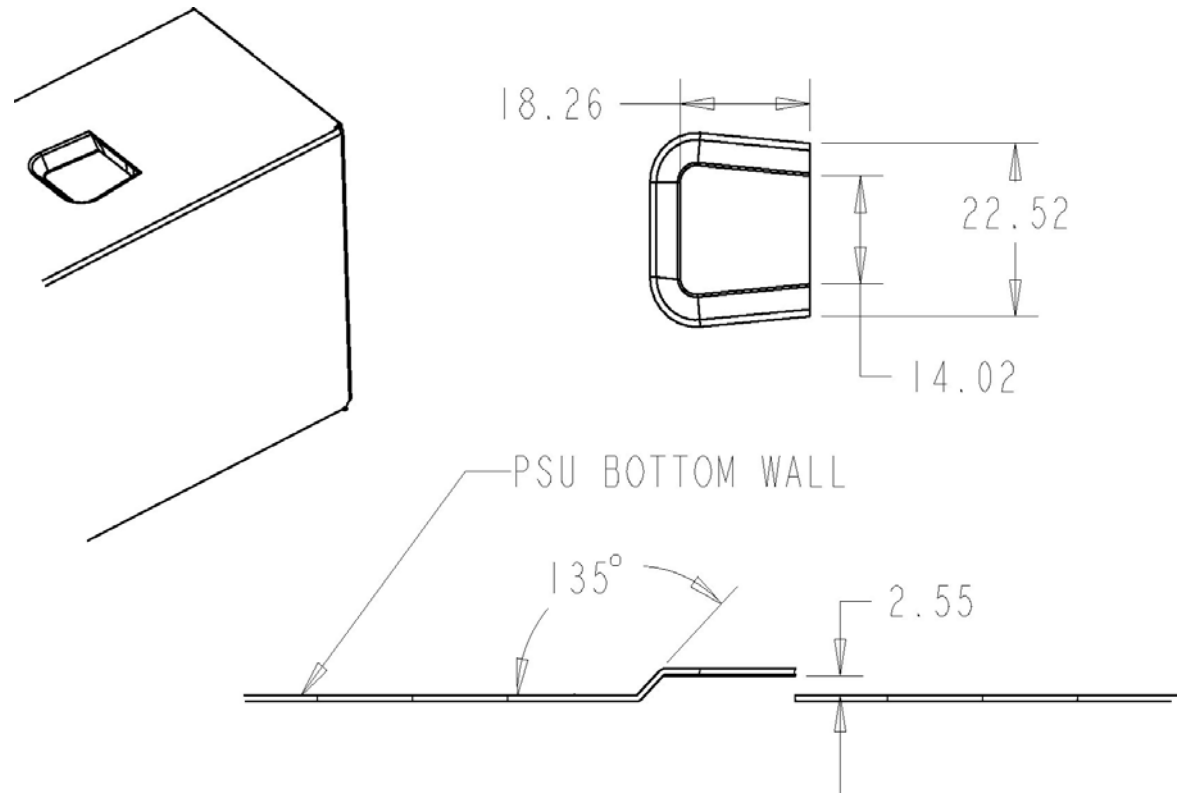

**Figure 11. Power Supply Mounting Slot Detail**

### 3.3 Mounting Options

The TFX12V mechanical design provides two options for mounting in a system chassis. The unit can be mounted using one of the mounting holes on the front end (non-vented end) or a chassis feature can be designed to engage the slot provided in the bottom of the supply. In order to accommodate different system chassis layouts, the TFX12V power supply is also designed to mount in two orientations (fan left and fan right) as shown in Figure 12. A mounting hole and slot should be provided for each orientation as shown in Figure 10. Details of a suggested geometry for the mounting slot are shown in Figure 11.

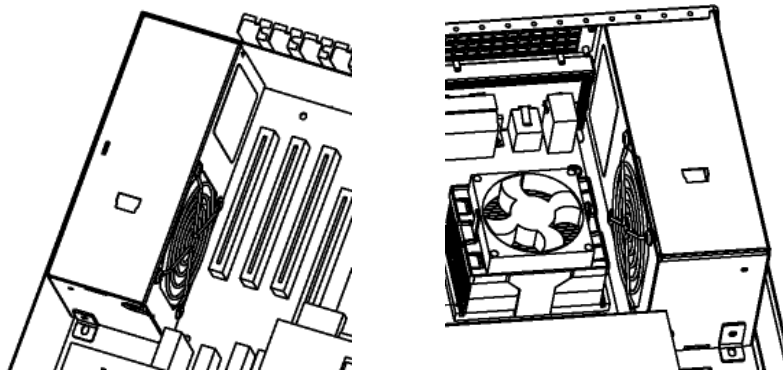

---

Figure 12. Fan Right and Fan Left Orientations of Power Supply in a Chassis

### 3.4 Chassis Requirements

To ensure the power supply can be easily integrated, the following features should be designed into a chassis intended to use a TFX12V power supply:

- Chassis cutout (normally in the rear panel of the chassis) as shown in Figure 13.
- EITHER a mounting bracket to interface with the forward mounting hole on the power supply OR a mounting tab as shown in Figure 14 to interface with the mounting slot on the bottom of the power supply

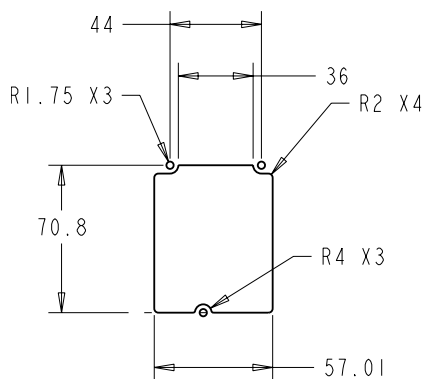

Figure 13. Suggested TFX12V Chassis Cutout

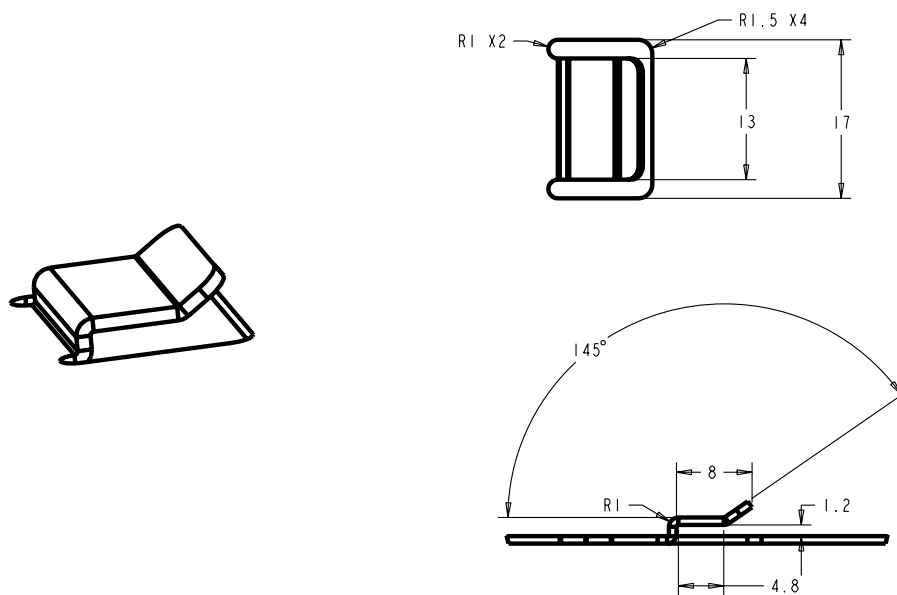

Figure 14. Suggested Mounting Tab (chassis feature)

## 3.5 Airflow / Fan

The designer's choice of a power supply cooling solution depends in part on the targeted end-use system application(s). At a minimum, the power supply design must ensure its own reliable and safe operation.

**Fan location/direction:** In general, exhausting air from the system chassis enclosure via a power supply fan is the preferred, most common, and most widely applicable system-level airflow solution. The location of the fan can have a large effect on how efficiently this air is exhausted. The location of the fan shown in Figure 10 allows the fan to be located close to the processor cooling solution when used in the common fan left configuration shown in Figure 12. This close proximity of the fan will aid in the evacuation of heated air and helps keep the total system cooler.

**Fan size/speed:** The TFX12V power supply has an 80 mm axial fan as shown in Figure 10. It is recommended that a thermally sensitive fan speed control circuit be used to balance system-level thermal and acoustic performance. The circuit typically senses the temperature of the secondary heat sink and/or incoming ambient air and adjusts the fan speed as necessary to keep power supply and system component temperatures within specifications. Both the power supply and system designers should be aware of the dependencies of the power supply and system temperatures on the control circuit response curve and fan size and should specify them carefully.

The power supply fan should be turned off when PS\_ON# is de-asserted (high). In this state, any remaining active power supply circuitry must rely only on passive convection for cooling.

**Venting:** In general, more venting in a power supply case yields reduced airflow impedance and improved cooling performance. Intake and exhaust vents should be as large, open, and unobstructed as possible so as not to impede airflow or generate excessive acoustic noise. In particular, avoid placing objects within 0.5 inches of the intake or exhaust of the fan itself. A raised wire fan grill is recommended instead of a stamped metal vent for improved airflow and reduced acoustic noise for the intake vent. Figure 10 shows the suggested TFX12V exhaust vent pattern.

Considerations to the previous venting guidelines are:

- Openings must be sufficiently designed to meet the safety requirements described in Section 5.
- Larger openings yield decreased EMI-shielding performance. The suggested pattern in Figure 10 sufficiently shields EMI in most power supplies, but the design should always be tested as outlined in Section 6.1.

### NOTE:

Venting in inappropriate locations can detrimentally allow airflow to bypass those areas where it is needed.

## 3.6 AC Connector

The AC input receptacle should be an IEC 320 type or equivalent. In lieu of a dedicated switch, the IEC 320 receptacle may be considered the mains disconnect.

### 3.7 DC Connectors

Figure 15 shows pin outs and profiles for typical TFX12V power supply DC harness connectors. The TFX12V requires an additional two-pin, power connector.

UL Listed or recognized component appliance wiring material rated min 85 °C, 300 VDC shall be used for all output wiring.

There are no specific requirements for output wire harness lengths, as these are largely a function of the intended end-use chassis, motherboard, and peripherals. Ideally, wires should be short to minimize electrical/airflow impedance and simplify manufacturing, yet they should be long enough to make all necessary connections without any wire tension (which can cause disconnections during shipping and handling). Recommended minimum harness lengths for general-use power supplies is 150 mm for all wire harnesses. Measurements are made from the exit port of the power supply case to the wire side of the first connector on the harness.

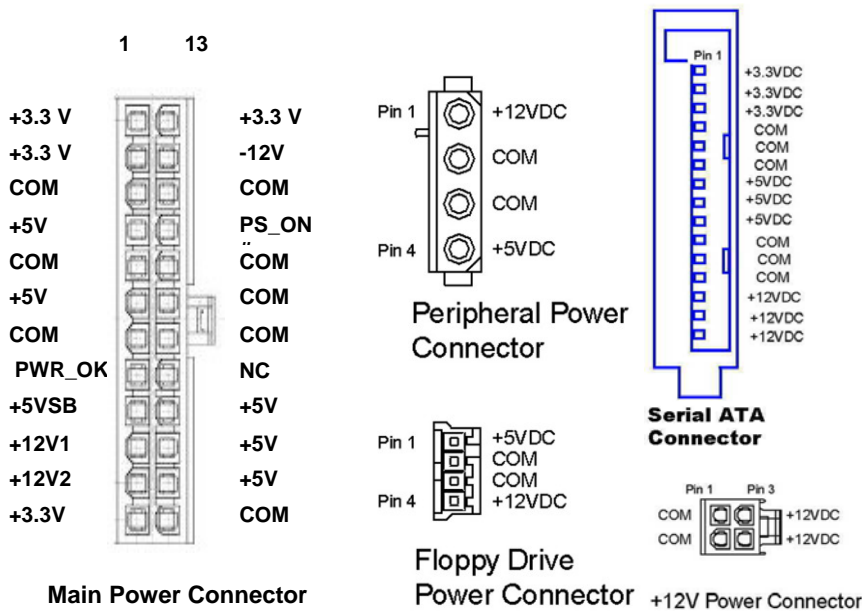

Figure 15. TFX12V Connectors (Pin-side view, not to scale)

### 3.7.1 TFX12V Main Power Connector

**Connector:** MOLEX\* 39-01-2240 or equivalent  
(Mating motherboard connector is Molex 44206-0007 or equivalent)

Contact: Molex 44476 Mini-fit, HCS, crimp terminal or equivalent

18 AWG is suggested for all wires except for the +3.3 V supply and sense return wires combined into pin 12 (22 AWG).

Pin	Signal	Color	Pin	Signal	Color
1	+3.3 VDC	Orange	13	+3.3 VDC [+3.3 V default sense]	Orange [Brown]
2	+3.3 VDC	Orange	14	-12 VDC	Blue
3	COM	Black	15	COM	Black
4	+5 VDC	Red	16	PS_ON#	Green
5	COM	Black	17	COM	Black
6	+5 VDC	Red	18	COM	Black
7	COM	Black	19	COM	Black
8	PWR_OK	Gray	20	Reserved	NC
9	+5 VSB	Purple	21	+5 VDC	Red
10	+12 V1DC	Yellow	22	+5 VDC	Red
11	+12 V1DC	Yellow	23	+5 VDC	Red
12	+3.3 VDC	Orange	24	COM	Black

### 3.7.2 Peripheral Connector(s)

**Connector:** AMP\* 1-480424-0 or MOLEX\* 8981-04P or equivalent.

**Contacts:** AMP 61314-1 or equivalent.

Pin	Signal	18 AWG Wire
1	+12 V1DC	Yellow
2	COM	Black
3	COM	Black
4	+5 VDC	Red

### 3.7.3 Floppy Drive Connector

**Connector:** AMP 171822-4 or equivalent

Pin	Signal	20 AWG Wire
1	+5 VDC	Red
2	COM	Black
3	COM	Black
4	+12 V1DC	Yellow

### 3.7.4 +12 V Power Connector

**Connector:** MOLEX 39-01-2040 or equivalent (Mating motherboard connector is Molex 39-29-9042 or equivalent)

**Contact:** Molex 44476 Mini-fit, HCS, crimp terminal or equivalent

Pin	Signal	18 AWG Wire	Pin	Signal	18 AWG Wire
1	COM	Black	3	+12 V2DC	Yellow /Black Stripe
2	COM	Black	4	+12 V2DC	Yellow /Black Stripe

### 3.7.5 Serial ATA Power Connector

This is an optional connector for systems with Serial ATA\* devices.

The detailed requirements for the Serial ATA Power Connector can be found in the “Serial ATA: High Speed Serialized AT Attachment” specification, Section 6.3 “Cables and connector specification”

**Assembly:** MOLEX 88751 or equivalent.

Wire	Signal	18 AWG Wire
5	+3.3 VDC	Orange
4	COM	Black
3	+5 VDC	Red
2	COM	Black
1	+12 V1DC	Yellow

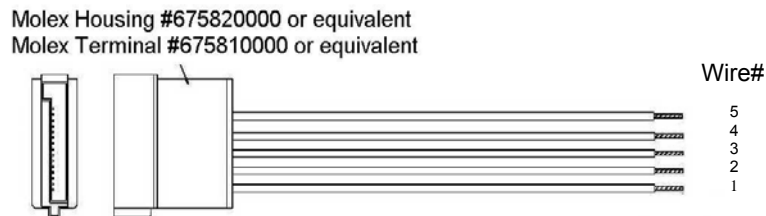

Figure 16. Serial ATA Connector

## 4 Environmental

---

The following subsections define recommended environmental specifications and test parameters, based on the typical conditions a TFX12V power supply unit may be subjected to during operation or shipment.

### 4.1 Temperature

**Operating ambient:** +10 °C to +50 °C (At full load, with a maximum temperature rate of change of 5 °C/10 minutes, but no more than 10 °C/hr.)

**Non-operating ambient:** -40 °C to +70 °C (Maximum temperature rate of change of 20 °C/hr.)

### 4.2 Thermal Shock (Shipping)

**Non-operating:** -40 °C to +70 °C

15 °C/min  $\leq$  Dt/dt  $\leq$  30 °C/min. Tested for 50 cycles; Duration of exposure to temperature extremes for each half cycle shall be 30 minutes.

### 4.3 Relative Humidity

**Operating:** To 85% relative humidity (non-condensing)

**Non-operating:** To 95% relative humidity (non-condensing)

**Note:** 95% RH is achieved with a dry bulb temperature of 55 °C and a wet bulb temperature of 54 °C.

### 4.4 Altitude Requirement

**Operating:** To 10,000 ft

**Non-operating:** To 50,000 ft

### 4.5 Mechanical Shock

**Non-operating:** 50 g, trapezoidal input; velocity change  $\geq$  170 in/s

Three drops on each of six faces are applied to each sample.

## 4.6 Random Vibration

**Non-operating:** 0.01 g<sup>2</sup>/Hz at 5 Hz, sloping to 0.02 g<sup>2</sup>/Hz at 20 Hz, and maintaining 0.02 g<sup>2</sup>/Hz from 20 Hz to 500 Hz. The area under the PSD curve is 3.13 gRMS. The duration shall be 10 minutes per axis for all three axes on all samples.

## 4.7 Acoustics

**Sound Power:** The power supply assembly shall not produce a declared sound power level greater than 3.8 BA. The recommended power supply acoustic targets are shown in Table 17. Sound power determination is to be performed at 43C, 50% of rated load, at sea level. This test point is chosen to represent the environment seen inside a typical system at the idle acoustic test condition, with the 43C being derived from the standard ambient assumption of 23C, with 20C added for the temperature rise within the system (what is typically seen by the inlet fan). The declared sound power level shall be measured according to ISO 7779 and reported according to ISO 9296.

**Pure Tones:** The power supply assembly shall not produce any prominent discrete tone determined according to ISO 7779, Annex D.

**Table 17: Recommended power supply acoustic targets**

	Idle	Typical (50% Load)	Max
Minimum	3.5	4.0	5.0
Target	3.0	3.8	4.5

## 4.8 Ecological Requirements

The following materials must not be used during design and/or manufacturing of this product:

- Cadmium shall not be used in painting or plating.
- Quaternary salt and PCB electrolytic capacitors shall not be used.
- CFC's or HFC's shall not be used in the design or manufacturing process.
- Mercury shall not be used.

## 5 Safety

---

The following subsections outline sample product regulations requirements for a typical power supply. Actual requirements will depend on the design, product end use, target geography, and other variables. Consult your company's Product Safety and Regulations department or an accredited third party safety certification agency for more details.

### 5.1 North America

The power supply must be certified by an NRTL (Nationally Recognized Testing Laboratory) for use in the USA and Canada under the following conditions:

- The supply must be recognized for use in Information Technology Equipment including Electrical Business Equipment per UL 60950-1 First Edition, (2003). The certification must include external enclosure testing for the AC receptacle side of the power supply.
- The supply must have a full complement of tests conducted as part of the certification, such as input current, leakage current, hi-pot, temperature, energy discharge test, transformer output characterization test (open-circuit voltage, short-circuit performance)), and abnormal testing (to include stalled-fan tests and voltage-select-switch mismatch).
- The enclosure must meet fire enclosure mechanical test requirements per clauses 2.9.1 and 4.2 of the above-mentioned standard.

Production hipot testing must be included as a part of the certification and indicated as such in the certification report.

There must not be unusual or difficult conditions of acceptability such as mandatory additional cooling or power de-rating. The insulation system shall not have temperatures exceeding their rating when tested in the end product.

The certification mark shall be marked on each power supply.

The power supply must be evaluated for operator-accessible secondary outputs (reinforced insulation) that meet the requirements for SELV..

The proper polarity between the AC input receptacle and any printed wiring boards connections must be maintained (that is, brown=line, blue=neutral, and green or green/yellow =earth/chassis).

### 5.2 International

The vendor must provide a complete CB certificate and test report to IEC 60950-1: 2001. The CB report must include ALL CB member country national deviations as appropriate for the target market. All evaluations and certifications must be for reinforced insulation between primary and secondary circuits.

## 6 Electromagnetic Compatibility

---

The following subsections outline applicable product regulatory requirements for the TFX12V power supply. Additional requirements may be applied dependent upon the design, product end use (e.g., medical equipment and hazardous locations), target geography, and other variables.

### 6.1 Emissions

The power supply shall comply with FCC Part 15, EN55022: 1998 and CISPR 22: 1997, meeting Class B for both conducted and radiated emissions with a 4 dB margin. Tests shall be conducted using a shielded DC output cable to a shielded load. The load shall be adjusted as follows for three tests: No load on each output; 50% load on each output; 100% load on each output. Tests will be performed at 100 VAC 50Hz, 120 VAC 60 Hz, and 230 VAC 50 Hz power.

### 6.2 Immunity

The power supply shall comply with *EN 55024:1998* and *CISPR 24* specifications prior to sale in the EU (European Union), Korea, and possibly other geographies.

## 6.3 Input Line Current Harmonic Content

For sales in the EU (European Union) the power supply shall meet the requirements of *EN61000-3-2 Class D and the Guidelines for the Suppression of Harmonics in Appliances and General Use Equipment Class D* for harmonic line current content at full rated power. See Table 18 for the harmonic limits.

**Table 18: Harmonic Limits, Class D Equipment**

	<i>Per: EN 61000-3-2</i>	<i>Per: JEIDA MITI</i>
Harmonic Order <i>n</i>	Maximum permissible Harmonic current at <u>230 VAC / 50 Hz</u> in Amps	Maximum permissible Harmonic current at <u>100VAC / 50 Hz</u> in Amps
Odd harmonics		
3	2.3	5.29
5	1.14	2.622
7	0.77	1.771
9	0.4	0.92
11	0.33	0.759
13	0.21	0.483
15 ≤ <i>n</i> ≤ 39	0.15 x (15/ <i>n</i> )	0.345 x (15/ <i>n</i> )

## 6.4 Magnetic Leakage Fields

A PFC choke magnetic leakage field should not cause any interference with a high-resolution computer monitor placed next to or on top of the end-use chassis.

## 6.5 Voltage Fluctuations and Flicker

The power supply shall meet the specified limits of the *EN61000-3-3 Specification* for voltage fluctuations and flicker for equipment drawing not more than 16 AAC, connected to low voltage distribution systems.

## 7 System Cooling Considerations

---

The power supply fan location allows the system designer to utilize the airflow to help cool critical components such as the processor and chipset. Please note that the fan pulls air from the system, instead of blowing hot air in, so components must be placed such that airflow is directed across critical components. Cables, etc must not impede airflow.

For more information on system thermal design, please refer to <http://www.formfactors.org/>.

## 8 Reliability

---

The de-rating process promotes quality and high reliability. All electronic components should be designed with conservative device d-ratings for use in commercial and industrial environments.

## 9 Applicable Documents

---

The following documents support this design guide as additional reference material.

Document Title	Description
FCC Rules Part 15, Class B	Title 47, Code of Federal Regulations, Part 15
ICES-003: 1997, Class B	Interference-Causing Equipment Standard – Digital Apparatus
EN 55022: 1998 + Amendment A1:2000 Class B	Information Technology Equipment – Radio disturbance characteristics – Limits and methods of measurement
CISPR 22: 1997, Class B	Information Technology Equipment – Radio disturbance characteristics – Limits and methods of measurement
AS/NZS 3548:1995, Class B	Information Technology Equipment – Radio disturbance characteristics – Limits and methods of measurement
EN 55024:1998	Information Technology Equipment – Immunity Characteristics – Limits and methods of measurement
IEC 60950-1: 2001	Safety of Information Technology Equipment
EN 60950: 2000	Safety of Information Technology Equipment
UL 60950-1 First Edition (2003)	Safety of Information Technology Equipment
CSA 22.2 No. 60950-1-03 First Edition	Safety of Information Technology Equipment