

# NLX Rail Design Suggestions

Version 1.0

---

## **IMPORTANT INFORMATION AND DISCLAIMERS**

1. INTEL CORPORATION (AND ANY CONTRIBUTOR) MAKES NO WARRANTIES WITH REGARD TO THIS NLX DOCUMENT AND IN PARTICULAR DOES NOT WARRANT OR REPRESENT THAT THIS DOCUMENT OR ANY PRODUCTS MADE IN CONFORMANCE WITH IT WILL WORK IN THE INTENDED MANNER. NOR DOES INTEL (OR ANY CONTRIBUTOR) ASSUME RESPONSIBILITY FOR ANY ERRORS THAT THE DOCUMENT MAY CONTAIN OR HAVE ANY LIABILITIES OR OBLIGATIONS FOR DAMAGES INCLUDING, BUT NOT LIMITED TO, SPECIAL, INCIDENTAL, INDIRECT, PUNITIVE, OR CONSEQUENTIAL DAMAGES WHETHER ARISING FROM OR IN CONNECTION WITH THE USE OF THIS DOCUMENT IN ANY WAY.
2. NO REPRESENTATIONS OR WARRANTIES ARE MADE THAT ANY PRODUCT BASED IN WHOLE OR IN PART ON THE DOCUMENT WILL BE FREE FROM DEFECTS OR SAFE FOR USE FOR ITS INTENDED PURPOSE. ANY PERSON MAKING, USING OR SELLING SUCH PRODUCT DOES SO AT HIS OR HER OWN RISK.
3. THE USER OF THIS DOCUMENT HEREBY EXPRESSLY ACKNOWLEDGES THAT THE DOCUMENT IS PROVIDED AS IS, AND THAT INTEL CORPORATION (AND ANY CONTRIBUTOR) MAKES NO REPRESENTATIONS, EXTENDS ANY WARRANTIES OF ANY KIND, EITHER EXPRESS OR IMPLIED, ORAL OR WRITTEN, INCLUDING ANY WARRANTY OF MERCHANTABILITY OR FITNESS FOR A PARTICULAR PURPOSE, OR WARRANTY OR REPRESENTATION THAT THE DOCUMENT OR ANY PRODUCT OR TECHNOLOGY UTILIZING THE DOCUMENT OR ANY SUBSET OF THE DOCUMENT WILL BE FREE FROM ANY CLAIMS OF INFRINGEMENT OF ANY INTELLECTUAL PROPERTY, INCLUDING PATENTS, COPYRIGHT AND TRADE SECRETS NOR DOES INTEL (OR ANY CONTRIBUTOR) ASSUME ANY OTHER RESPONSIBILITIES WHATSOEVER WITH RESPECT TO THE DOCUMENT OR SUCH PRODUCTS.
4. A LICENSE IS HEREBY GRANTED TO COPY AND REPRODUCE THIS DOCUMENT FOR ANY PURPOSE PROVIDED THIS "IMPORTANT INFORMATION AND DISCLAIMERS" SECTION (PARAGRAPHS 1-4) IS PROVIDED IN WHOLE. NO OTHER LICENSE, EXPRESS OR IMPLIED, BY ESTOPPEL OR OTHERWISE, TO ANY OTHER INTELLECTUAL PROPERTY RIGHTS IS GRANTED HEREIN.

Copyright © 1997 Intel Corporation. All rights reserved.

Release 1.0, May 1997

† Other product and corporate names may be trademarks or registered trademarks of other companies, and are used only for explanation and to the owners' benefit, without intent to infringe.

# Contents

---

- 1 Objective ..... 4**
- 2 Rail Requirements and Functions ..... 4**
- 3 Rail Mechanical Specification ..... 5**
  - 3.1 Rail Height, Mounting Thread Size, and Locations..... 5
  - 3.2 Component Height Clearance..... 5
  - 3.3 EMI/RFI Ground Clip ..... 5
- 4 Molded Plastic Rail Design..... 6**
- 5 Rail Ground EMI/RFI Clip ..... 7**
- 6 Assembly Rail-Ground Clips ..... 8**
- 7 Assembly Cross Section ..... 9**
- 8 Molded Plastic Lever-latch ..... 10**
- 9 Assembly Lever-latch ..... 11**

## List of Figures

- Figure 1: Molded Plastic Rail Example..... 6
- Figure 2: Rail Ground Clip Example..... 7
- Figure 3: Rail and Clip Assembly ..... 8
- Figure 4: Cross Section Through Rail Assembly ..... 9
- Figure 5: Molded Lever-latch Example..... 10
- Figure 6: Lever-Latch Assembly..... 11

# 1. Objective

---

The NLX motherboard specification does not require any specific method of mounting the motherboard to the chassis. The preferred method is to use a rail system. This paper describes design considerations for developing rails used to mount the motherboard to the chassis in an NLX slide-mount system.

Implementation examples show use of an injection-molded plastic rail, lever-latch, and embedded metal ground clips for the rails.

# 2. Rail Requirements and Functions

---

Two rails are required for mounting a motherboard. The rails generally perform the following functions:

- Mount the motherboard to the chassis.
- Provide mechanical support for motherboard insertion/extraction.
- Provide features for EMI/RFI ground clips.

## 3. Rail Mechanical Specification

---

This section describes the mechanical specifications for an NLX motherboard rail.

### 3.1 Rail Height, Mounting Thread Size, and Locations

The NLX motherboard specification defines the height of the motherboard from the chassis bottom to be .331 inch/ 7.95 mm. An NLX motherboard uses four mounting holes to attach it to the mounting system, requiring two rails. Each rail has two mounting bosses at 3.400 inch/ 86.36 mm centers. The overall rail height at the mounting bosses should be .331 inch/7.95 mm.

There are various methods for attaching the rails to the motherboard. This paper considers only a screw-mounted rail. The screws are used to secure the rail to the motherboard. The thread size for screws should be #6-32. In case of plastic rails, an additional rib should be provided to help support the motherboard. The rib height should match .313 inch/7.95 mm so that the rib makes contact with the motherboard and absorbs some of the shock during shipping. See Figure 1 for details.

### 3.2 Component Height Clearance

The NLX motherboard specification requires that there be a .140 inch/3.56 mm clearance between the bottom of the board to the top of the entire length of rail except at mounting bosses and support rib.

### 3.3 EMI/RFI Ground Clip

It is suggested that EMI/RFI grounding contacts be used in the rails. These metal contacts are used to provide grounding from the motherboard mounting holes to the chassis through clips attached to the rails. In this design example, there are features provided in the rail for snap-on EMI/RFI ground clips.



## 5. Rail Ground EMI/RFI Clip

---

Figure 2 shows an example of the EMI/RFI ground clips used in the rails. The clip is snapped on the rail before the rail is attached to the motherboard. In general, the material used for the clip should provide an electrical path to ground, and it should be made of a resilient material such as stainless steel to ensure good contact. The clip can be made of .008 inch/0.20 mm, half-hard 301 stainless steel material. The 0.158 inch diameter hole provides clearance for a #6-32 screw. The radius portion of the clip assembly provides a sufficient contact surface for EMI/RFI grounding of the motherboard. There are four contact surfaces per assembly in this design method.

---

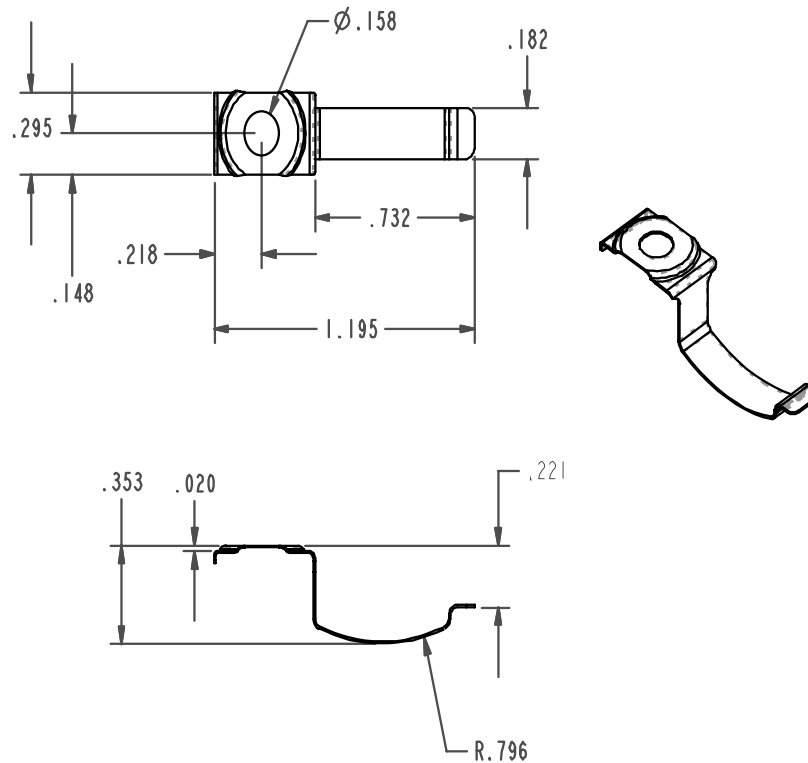

---

**Figure 2: Rail Ground Clip Example**

Note: Measurements are in inches.

# 6. Assembly Rail-Ground Clips

---

Figure 3 shows an example of two ground clips snapped into the motherboard rail.

---

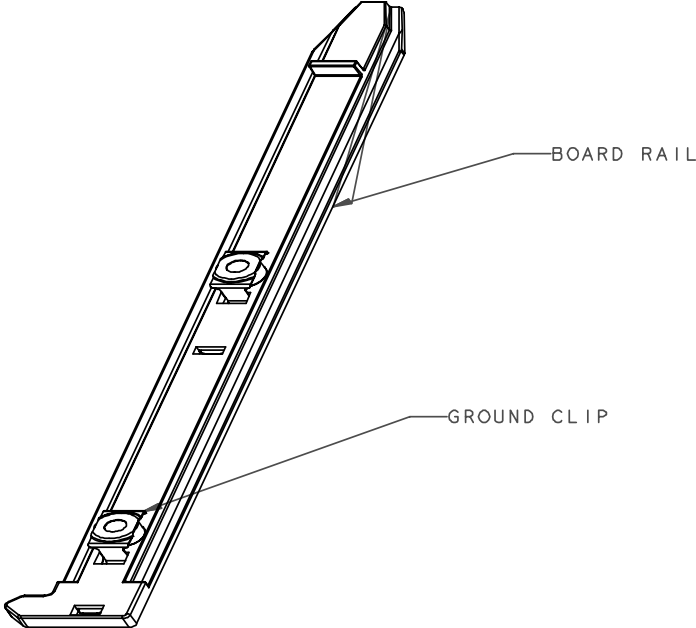

---

**Figure 3: Rail and Clip Assembly**

## 7. Assembly Cross Section

Figure 4 shows the cross section through the motherboard, rail, ground clip, and chassis assembly.

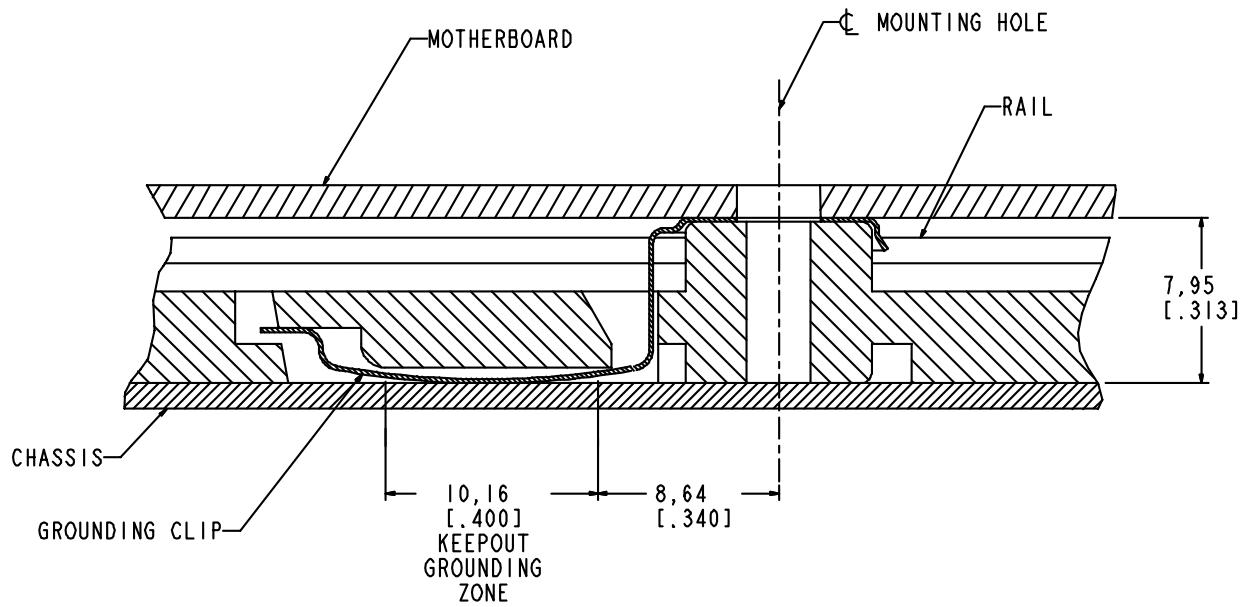
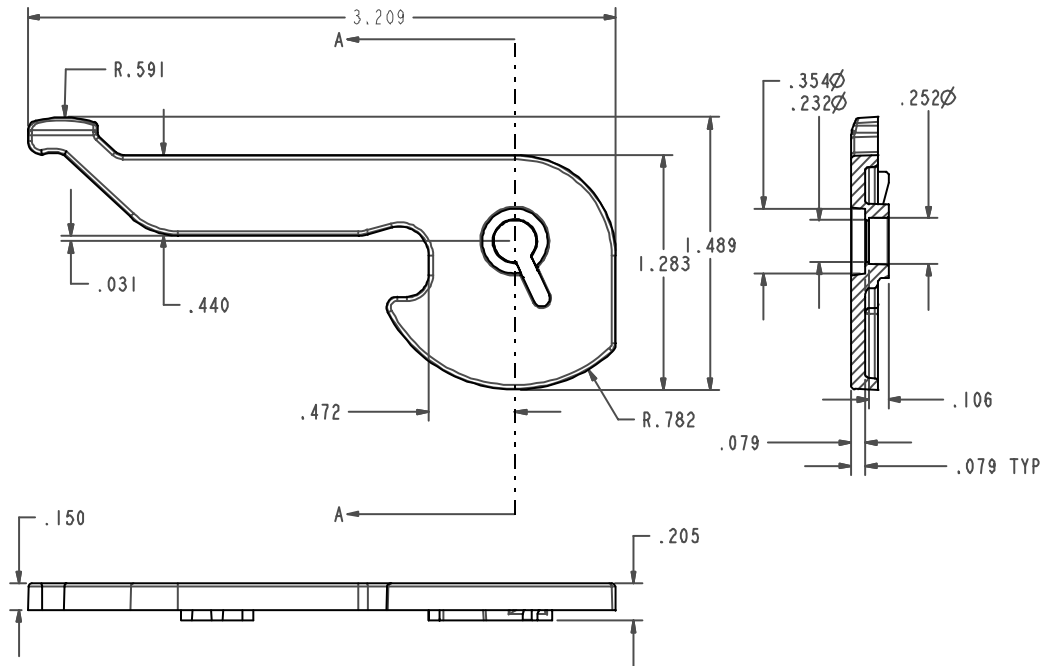

Figure 4: Cross Section Through Rail Assembly

## 8. Molded Plastic Lever-latch

Figure 5 shows an example of an injection molded lever-latch. The lever-latch is used to give a mechanical advantage over the connector during insertion and extraction of the motherboard as well as latch the motherboard in during normal operation.



**Figure 5: Molded Lever-latch Example**

Note: Measurements are in inches.

## 9. Assembly Lever-latch

Figure 6 shows an example of a lever-latch assembly. The lever-latch is mounted in the chassis and hooks to the rail. The mounting point acts as a pivot for the lever-latch.

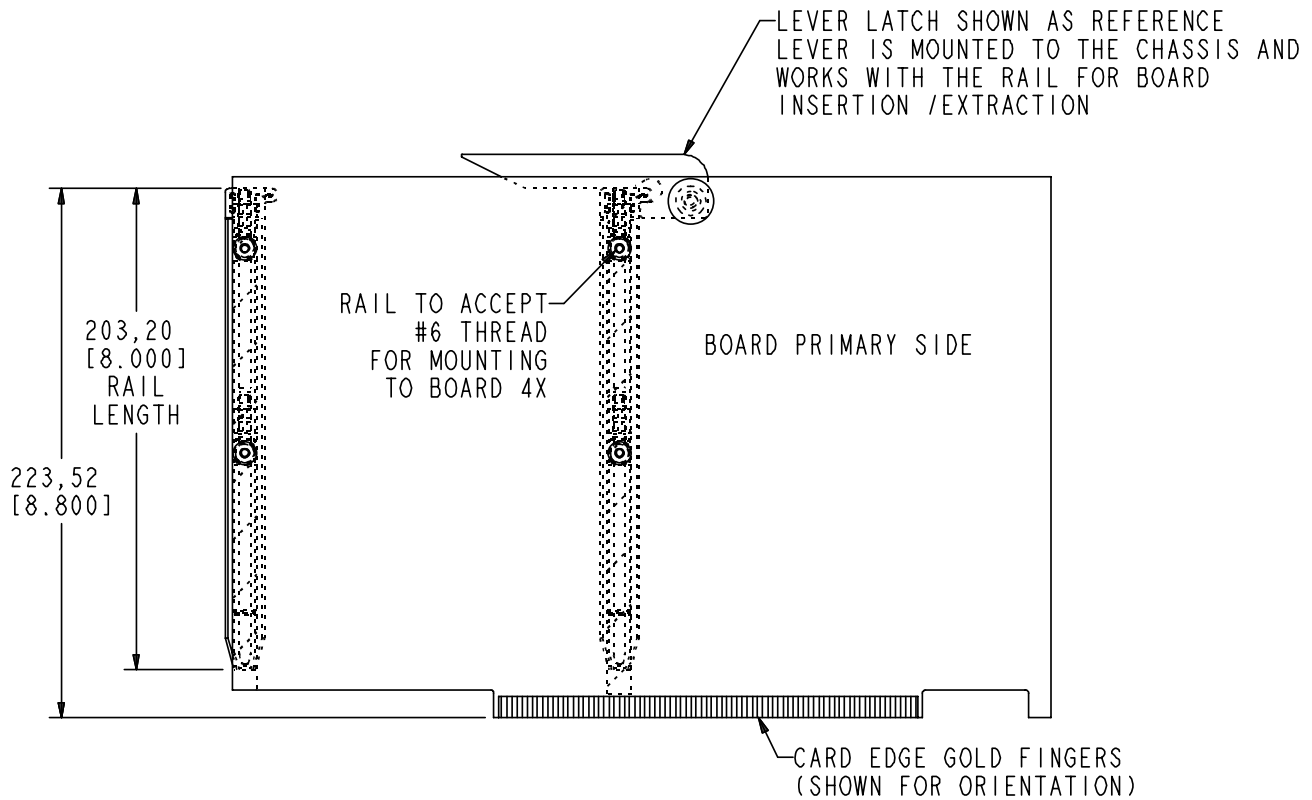

Figure 6: Lever-Latch Assembly